

L:

- CBL-USPD302MBSS-0.5m 500mm±10mm
- CBL-USPD302MBSS-1m 1000mm±10mm
- CBL-USPD302MBSS-2m 2000mm±20mm
- CBL-USPD302MBSS-3m 3000mm±20mm

No	MATERIALS LIST:
1.	CABLE:UL2725 (32AWG*1PR+D+AM)x2C+32AWG*1PR+24AWG*1C+AM+B OD:4.2mm PVC JACKET COLOR:BLUE
2.	CONNECTOR:USB 3.0 A/M, 9P, BLUE INSULATOR SOLDER TYPE, NICKEL PLATED SHELL
3.	CONNECTOR:USB 3.0 MicroB/M, 10P, BLACK INSULATOR SOLDER TYPE, NICKEL PLATED SHELL
4.	PVC MOLDED HOUSING, BLUE COLOR
5.	SCREW:#4x33 M2
6.	SCREW:#4x34.5 M2

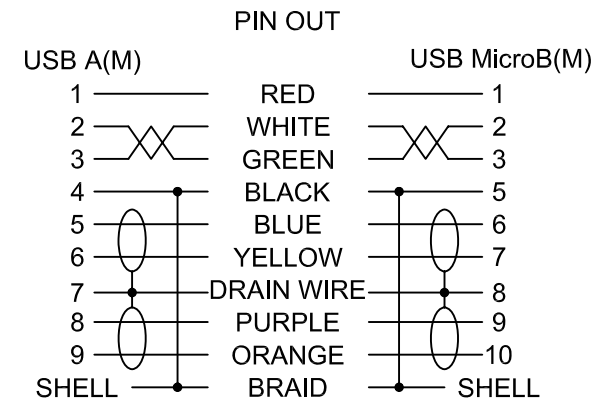

Jargy part no.	Client part no.	Approved	SCALE	UNIT
CBL-USPD302MBSS-Xm			1 : 1	mm
Drawing Name		Drawn	Date	REV.
USB 3.0 A to MicroB Cable M/M		<i>Kevin Hsu</i>	2015/08/12	1.0

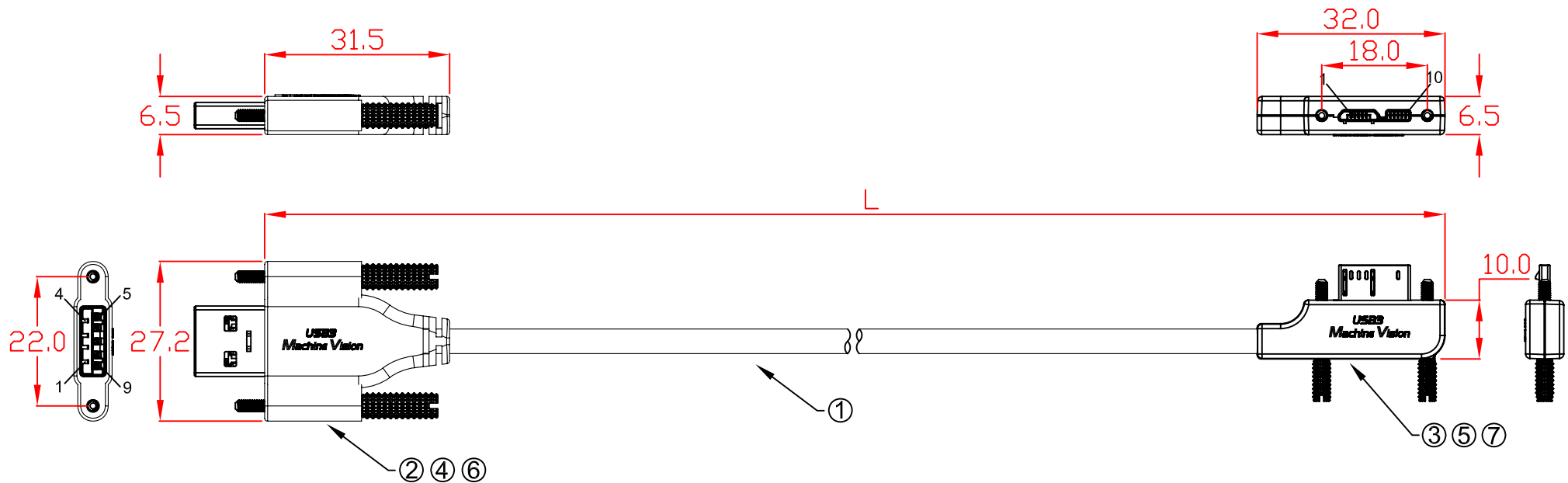

L:

- CBL-USPD302MBSS-0.5mLA 500mm±10mm
- CBL-USPD302MBSS-1mLA 1000mm±10mm
- CBL-USPD302MBSS-2mLA 2000mm±20mm
- CBL-USPD302MBSS-3mLA 3000mm±20mm

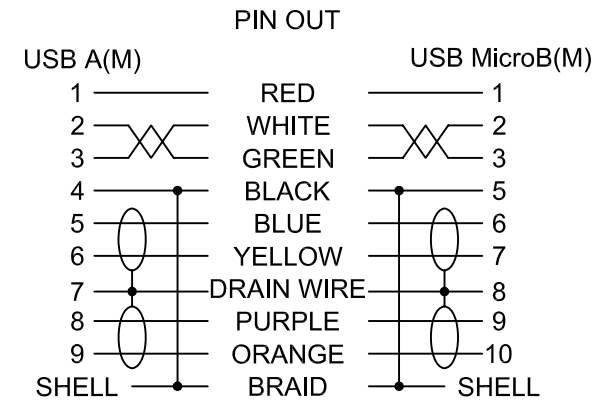

No	MATERIALS LIST:
1.	CABLE:UL2725 (32AWG*1PR+D+AM)x2C+32AWG*1PR+24AWG*1C+AM+B OD:4.2mm PVC JACKET COLOR:BLUE
2.	CONNECTOR:USB 3.0 A/M, 9P, BLUE INSULATOR SOLDER TYPE, NICKEL PLATED SHELL
3.	CONNECTOR:USB 3.0 MicroB/M, 10P, BLACK INSULATOR SOLDER TYPE, NICKEL PLATED SHELL
4.	PVC MOLDED HOUSING, BLUE COLOR
5.	ABS ASSEMBLY HOUSING, BLUE COLOR
6.	SCREW:#4x34.5 M2
7.	SCREW:#3x20.7 M2

Jargy part no.	Client part no.	Approved	SCALE	UNIT
CBL-USPD302MBSS-XmLA			1 : 1	mm
Drawing Name		Drawn	Date	REV.
USB 3.0 A to Micro-B Cable M/M		<i>Kevin Hsu</i>	2016/06/03	1.0

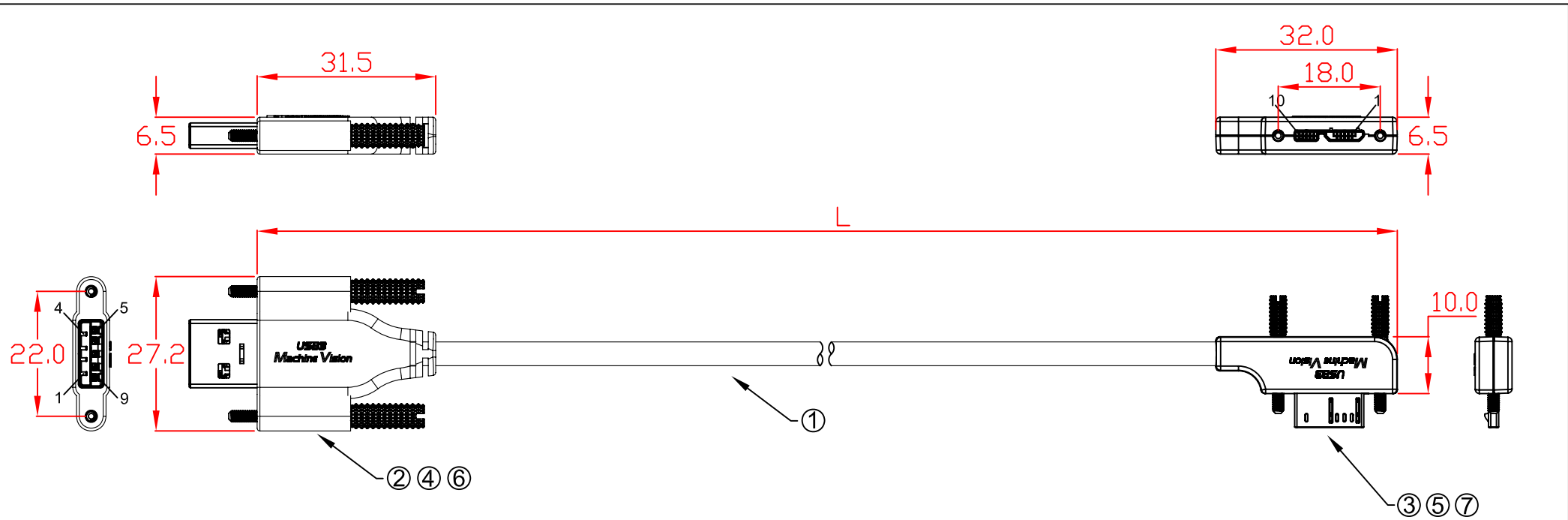

L:

- CBL-USPD302MBSS-0.5mRA 500mm±10mm
- CBL-USPD302MBSS-1mRA 1000mm±10mm
- CBL-USPD302MBSS-2mRA 2000mm±20mm
- CBL-USPD302MBSS-3mRA 3000mm±20mm

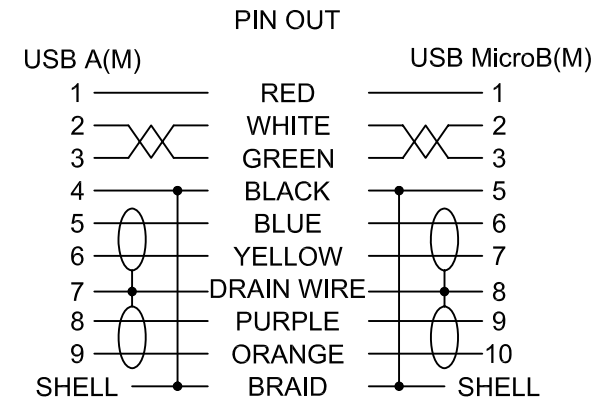

No	MATERIALS LIST:
1.	CABLE:UL2725 (32AWG*1PR+D+AM)x2C+32AWG*1PR+24AWG*1C+AM+B OD:4.2mm PVC JACKET COLOR:BLUE
2.	CONNECTOR:USB 3.0 A/M, 9P, BLUE INSULATOR SOLDER TYPE, NICKEL PLATED SHELL
3.	CONNECTOR:USB 3.0 MicroB/M, 10P, BLACK INSULATOR SOLDER TYPE, NICKEL PLATED SHELL
4.	PVC MOLDED HOUSING, BLUE COLOR
5.	ABS ASSEMBLY HOUSING, BLUE COLOR
6.	SCREW:#4x34.5 M2
7.	SCREW:#3x20.7 M2

Jargy part no.	Client part no.	Approved	SCALE	UNIT
CBL-USPD302MBSS-XmRA			1 : 1	mm
Drawing Name		Drawn	Date	REV.
USB 3.0 A to Micro-B Cable M/M		<i>Kevin Hsu</i>	2016/06/03	1.0

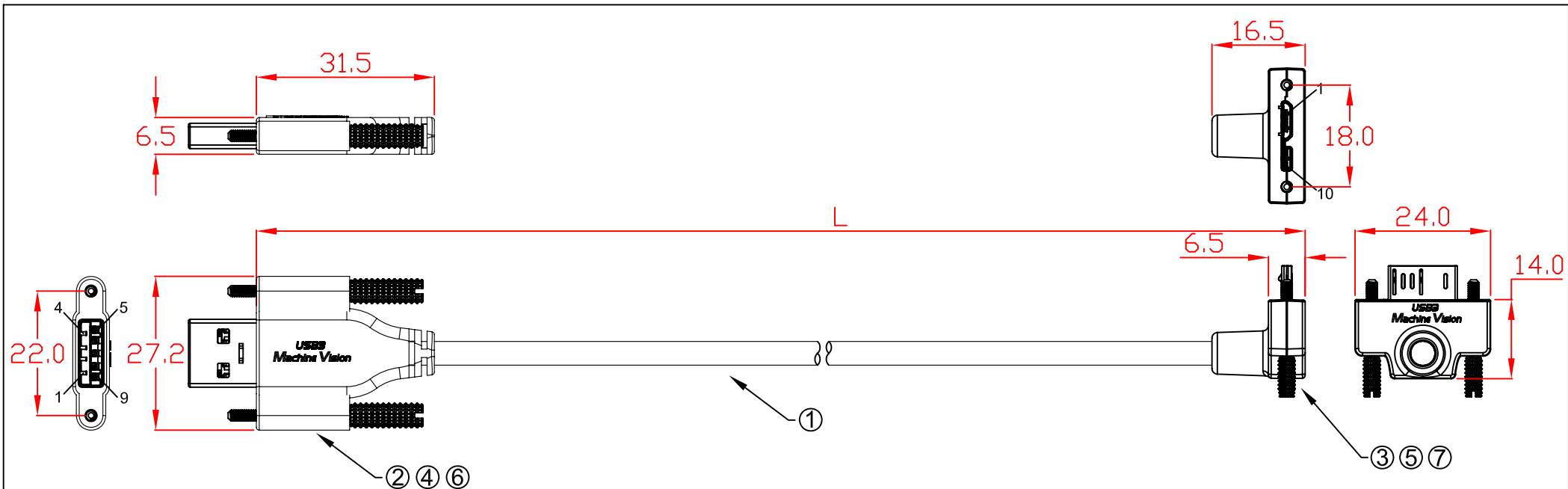

L:

- CBL-USPD302MBSS-0.5mUA 500mm±10mm
- CBL-USPD302MBSS-1mUA 1000mm±10mm
- CBL-USPD302MBSS-2mUA 2000mm±20mm
- CBL-USPD302MBSS-3mUA 3000mm±20mm

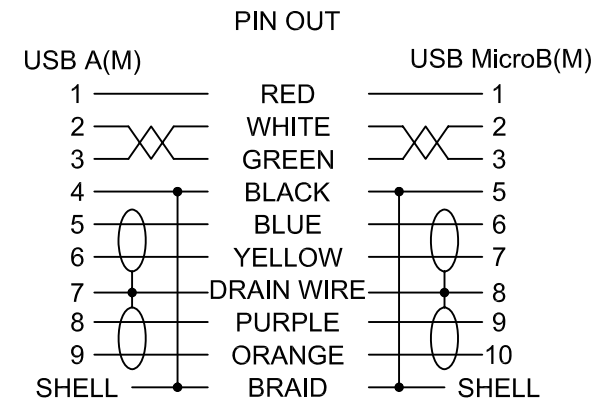

No	MATERIALS LIST:
1.	CABLE:UL2725 (32AWG*1PR+D+AM)x2C+32AWG*1PR+24AWG*1C+AM+B OD:4.2mm PVC JACKET COLOR:BLUE
2.	CONNECTOR:USB 3.0 A/M, 9P, BLUE INSULATOR SOLDER TYPE, NICKEL PLATED SHELL
3.	CONNECTOR:USB 3.0 MicroB/M, 10P, BLACK INSULATOR SOLDER TYPE, NICKEL PLATED SHELL
4.	PVC MOLDED HOUSING, BLUE COLOR
5.	ABS ASSEMBLY HOUSING, BLUE COLOR
6.	SCREW:#4x34.5 M2
7.	SCREW:#3x20.7 M2

Jargy part no.	Client part no.	Approved	SCALE	UNIT
CBL-USPD302MBSS-XmUA			1 : 1	mm
Drawing Name		Drawn	Date	REV.
USB 3.0 A to Micro-B Cable M/M		<i>Kevin Hsu</i>	2016/06/03	1.0

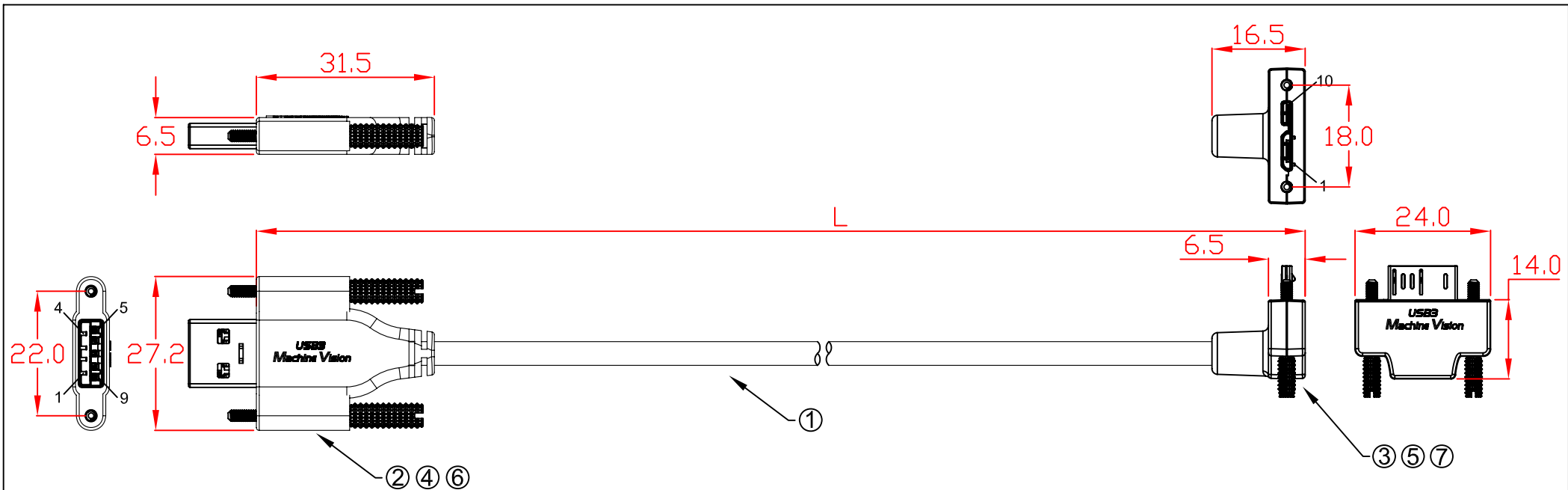

L:

- CBL-USPD302MBSS-0.5mDA 500mm±10mm
- CBL-USPD302MBSS-1mDA 1000mm±10mm
- CBL-USPD302MBSS-2mDA 2000mm±20mm
- CBL-USPD302MBSS-3mDA 3000mm±20mm

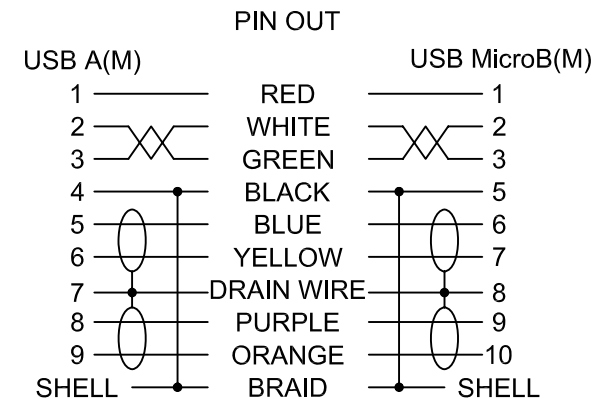

No	MATERIALS LIST:
1.	CABLE:UL2725 (32AWG*1PR+D+AM)x2C+32AWG*1PR+24AWG*1C+AM+B OD:4.2mm PVC JACKET COLOR:BLUE
2.	CONNECTOR:USB 3.0 A/M, 9P, BLUE INSULATOR SOLDER TYPE, NICKEL PLATED SHELL
3.	CONNECTOR:USB 3.0 MicroB/M, 10P, BLACK INSULATOR SOLDER TYPE, NICKEL PLATED SHELL
4.	PVC MOLDED HOUSING, BLUE COLOR
5.	ABS ASSEMBLY HOUSING, BLUE COLOR
6.	SCREW:#4x34.5 M2
7.	SCREW:#3x20.7 M2

Jargy part no.	Client part no.	Approved	SCALE	UNIT
CBL-USPD302MBSS-XmDA			1 : 1	mm
Drawing Name		Drawn	Date	REV.
USB 3.0 A to Micro-B Cable M/M		<i>Kevin Hsu</i>	2016/06/03	1.0

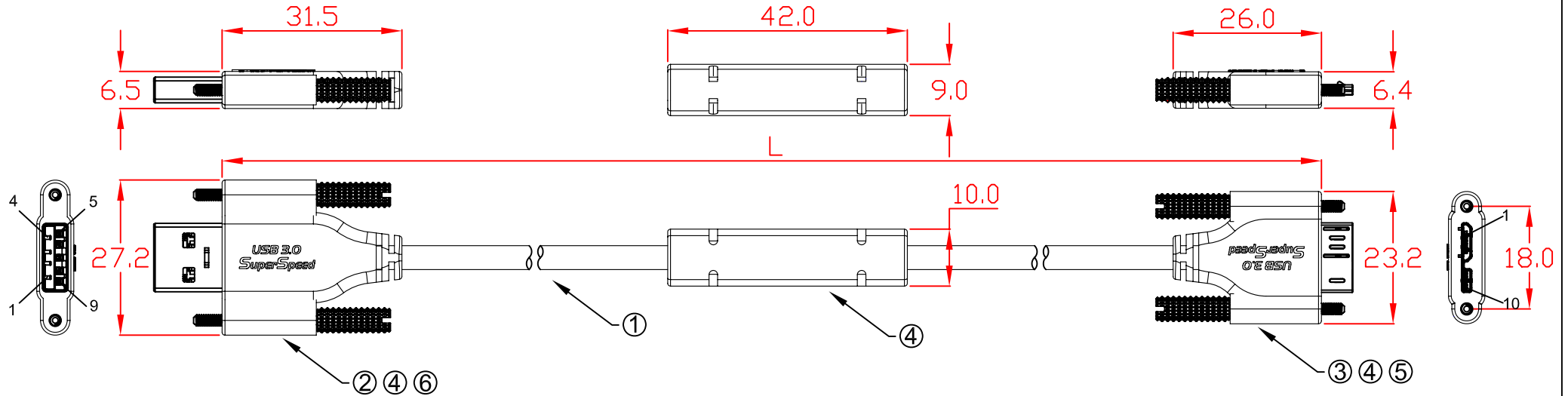

L:

- CBL-USD302MBSS-4m 4000mm±20mm
- CBL-USD302MBSS-5m 5000mm±30mm
- CBL-USD302MBSS-6m 6000mm±30mm
- CBL-USD302MBSS-7m 7000mm±30mm
- CBL-USD302MBSS-8m 8000mm±30mm

No	MATERIALS LIST:
1.	CABLE:UL2725 (32AWG*1PR+D+AM)x2C+32AWG*1PR+24AWG*1C+AM+B OD:4.2mm PVC JACKET COLOR:BLUE
2.	CONNECTOR:USB 3.0 A/M, 9P, BLUE INSULATOR SOLDER TYPE, NICKEL PLATED SHELL
3.	CONNECTOR:USB 3.0 MicroB/M, 10P, BLACK INSULATOR SOLDER TYPE, NICKEL PLATED SHELL
4.	PVC MOLDED HOUSING, BLUE COLOR
5.	SCREW:#4x33 M2
6.	SCREW:#4x34.5 M2

PIN OUT

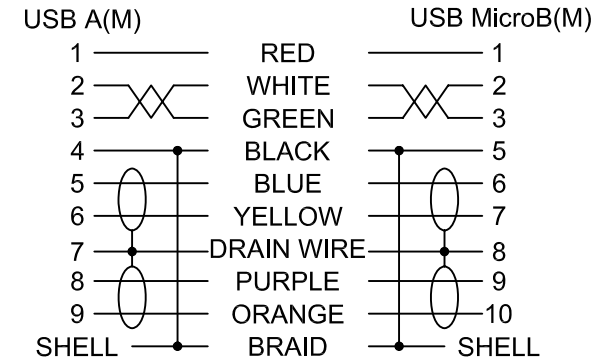

Jargy part no.	Client part no.	Approved	SCALE	UNIT
CBL-USD302MBSS-Xm			1 : 1	mm
Drawing Name		Drawn	Date	REV.
USB 3.0 A to MicroB Cable M/M		<i>Kevin Hsu</i>	2015/08/12	1.0

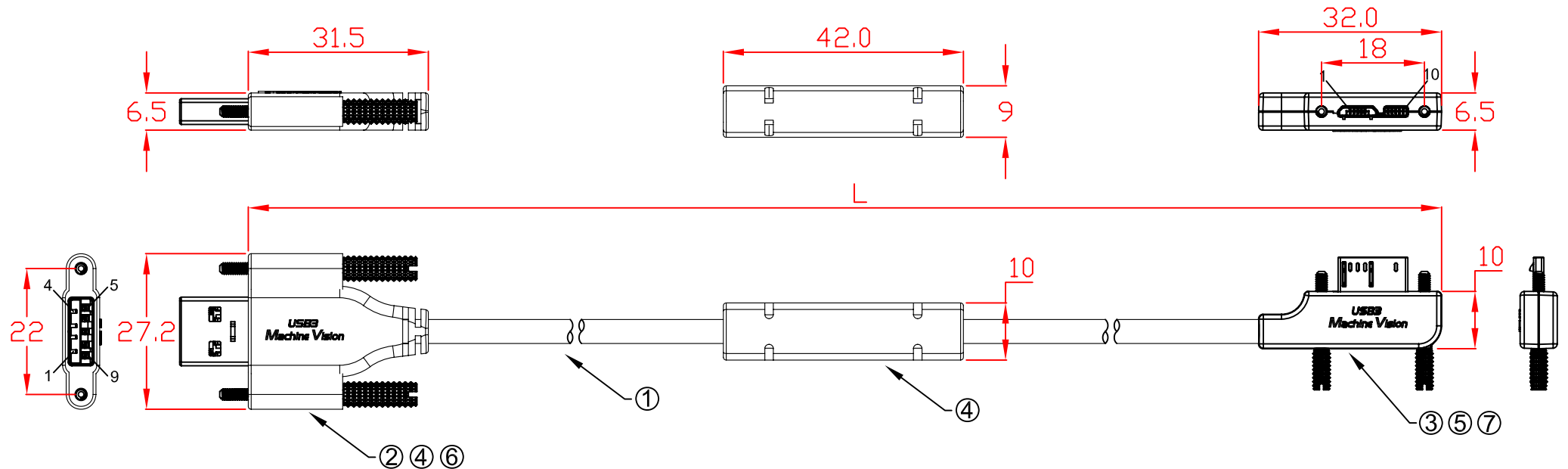

L:

- CBL-USD302MBSS-4mLA 4000mm±30mm
- CBL-USD302MBSS-5mLA 5000mm±30mm
- CBL-USD302MBSS-6mLA 6000mm±30mm
- CBL-USD302MBSS-7mLA 7000mm±30mm
- CBL-USD302MBSS-8mLA 8000mm±30mm

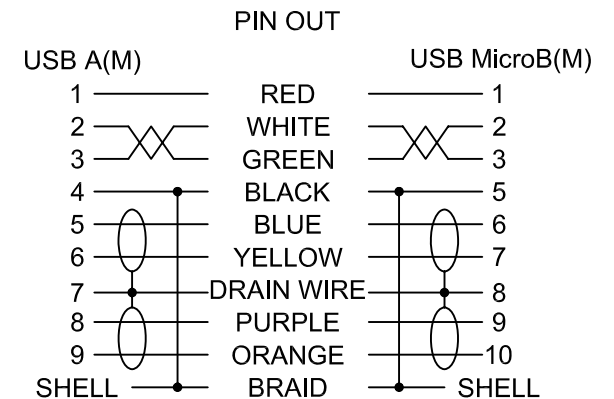

No	MATERIALS LIST:
1.	CABLE:UL2725 (32AWG*1PR+D+AM)x2C+32AWG*1PR+24AWG*1C+AM+B OD:4.2mm PVC JACKET COLOR:BLUE
2.	CONNECTOR:USB 3.0 A/M, 9P, BLUE INSULATOR SOLDER TYPE, NICKEL PLATED SHELL
3.	CONNECTOR:USB 3.0 MicroB/M, 10P, BLACK INSULATOR SOLDER TYPE, NICKEL PLATED SHELL
4.	PVC MOLDED HOUSING, BLUE COLOR
5.	ABS ASSEMBLY HOUSING, BLUE COLOR
6.	SCREW:#4x34.5 M2
7.	SCREW:#3x20.7 M2

Jargy part no.	Client part no.	Approved	SCALE	UNIT
CBL-USD302MBSS-XmLA			1 : 1	mm
Drawing Name		Drawn	Date	REV.
USB 3.0 A to Micro-B Cable M/M		<i>Kevin Hsu</i>	2016/06/04	1.0

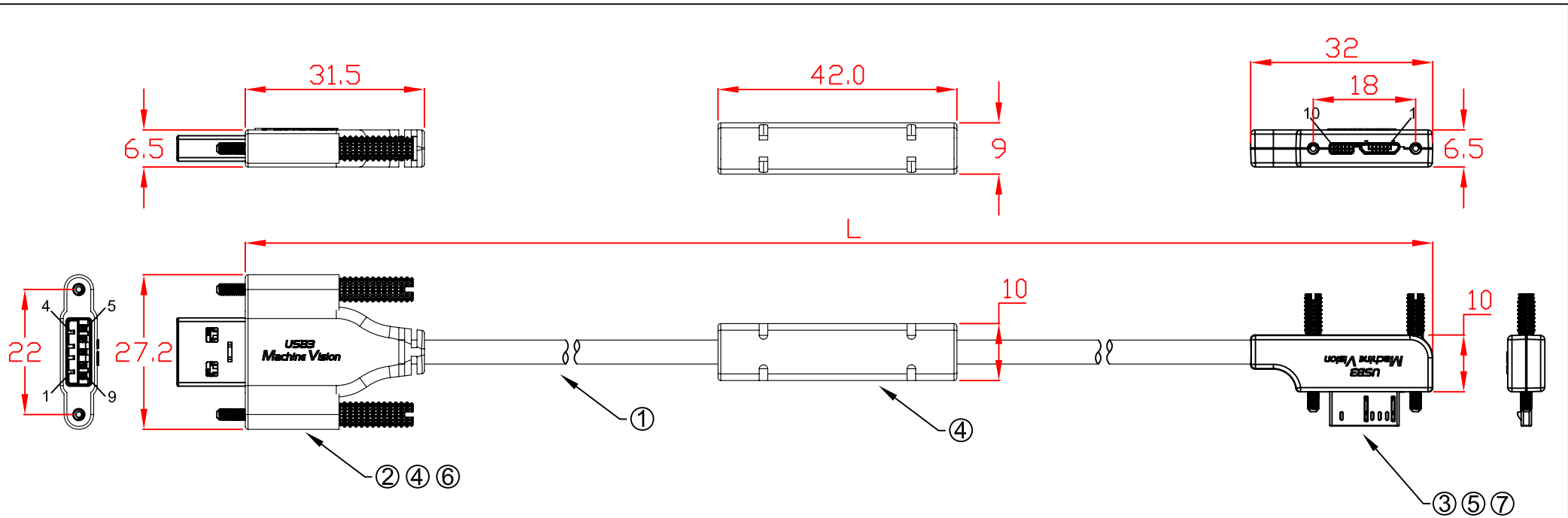

L:

- CBL-USD302MBSS-4mRA 4000mm±30mm
- CBL-USD302MBSS-5mRA 5000mm±30mm
- CBL-USD302MBSS-6mRA 6000mm±30mm
- CBL-USD302MBSS-7mRA 7000mm±30mm
- CBL-USD302MBSS-8mRA 8000mm±30mm

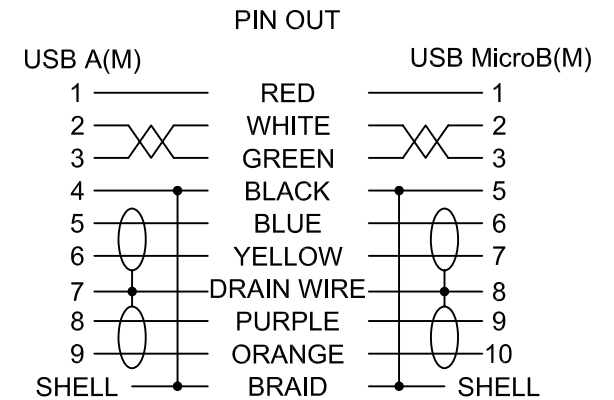

No	MATERIALS LIST:
1.	CABLE:UL2725 (32AWG*1PR+D+AM)x2C+32AWG*1PR+24AWG*1C+AM+B OD:4.2mm PVC JACKET COLOR:BLUE
2.	CONNECTOR:USB 3.0 A/M, 9P, BLUE INSULATOR SOLDER TYPE, NICKEL PLATED SHELL
3.	CONNECTOR:USB 3.0 MicroB/M, 10P, BLACK INSULATOR SOLDER TYPE, NICKEL PLATED SHELL
4.	PVC MOLDED HOUSING, BLUE COLOR
5.	ABS ASSEMBLY HOUSING, BLUE COLOR
6.	SCREW:#4x34.5 M2
7.	SCREW:#3x20.7 M2

Jargy part no.	Client part no.	Approved	SCALE	UNIT
CBL-USD302MBSS-XmRA			1 : 1	mm
Drawing Name		Drawn	Date	REV.
USB 3.0 A to Micro-B Cable M/M		<i>Kevin Hsu</i>	2016/06/04	1.0



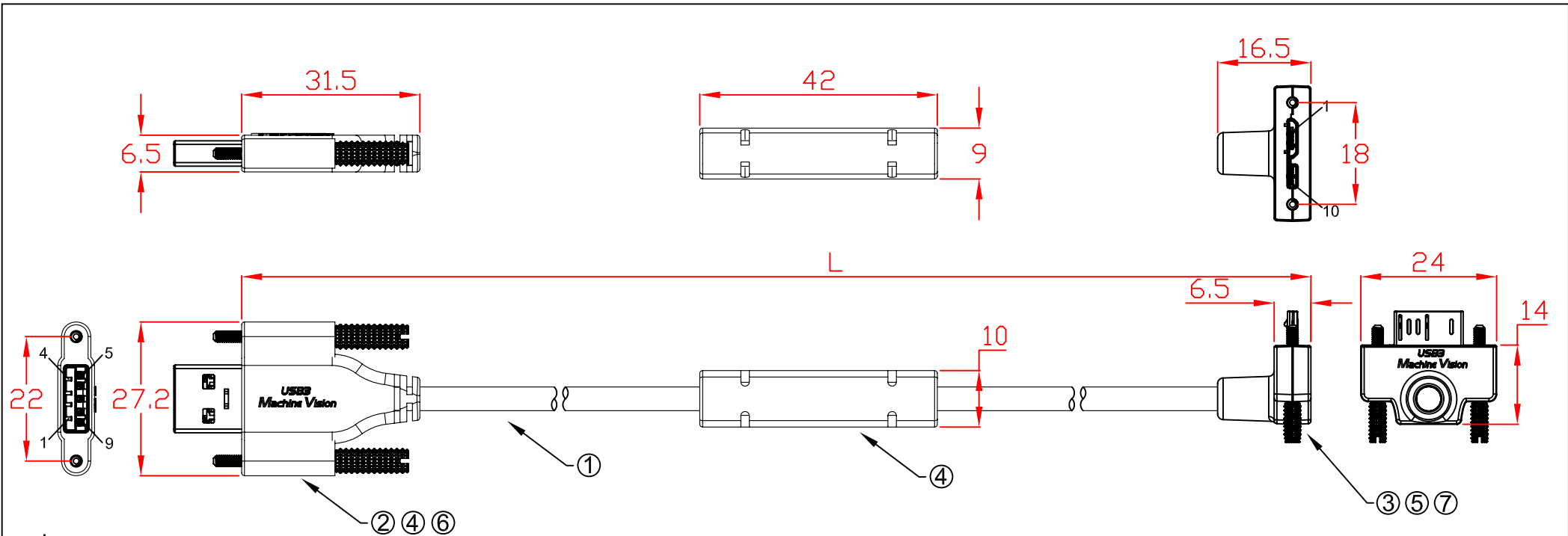

L:

- CBL-USD302MBSS-4mUA 4000mm±30mm
- CBL-USD302MBSS-5mUA 5000mm±30mm
- CBL-USD302MBSS-6mUA 6000mm±30mm
- CBL-USD302MBSS-7mUA 7000mm±30mm
- CBL-USD302MBSS-8mUA 8000mm±30mm

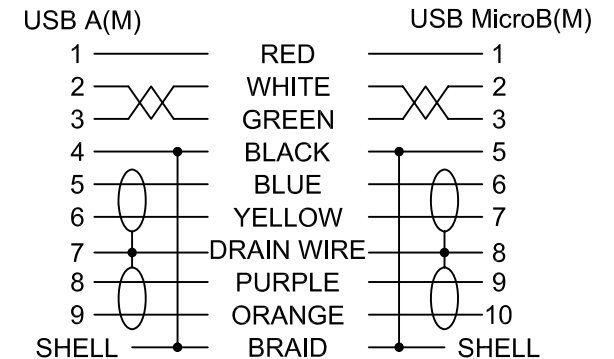

No	MATERIALS LIST:
1.	CABLE:UL2725 (32AWG*1PR+D+AM)x2C+32AWG*1PR+24AWG*1C+AM+B OD:4.2mm PVC JACKET COLOR:BLUE
2.	CONNECTOR:USB 3.0 A/M, 9P, BLUE INSULATOR SOLDER TYPE, NICKEL PLATED SHELL
3.	CONNECTOR:USB 3.0 MicroB/M, 10P, BLACK INSULATOR SOLDER TYPE, NICKEL PLATED SHELL
4.	PVC MOLDED HOUSING, BLUE COLOR
5.	ABS ASSEMBLY HOUSING, BLUE COLOR
6.	SCREW:#4x34.5 M2
7.	SCREW:#3x20.7 M2

Jargy part no.	Client part no.	Approved	SCALE	UNIT
CBL-USD302MBSS-XmUA			1 : 1	mm
Drawing Name		Drawn	Date	REV.
USB 3.0 A to Micro-B Cable M/M		<i>Kevin Hsu</i>	2016/06/04	1.0

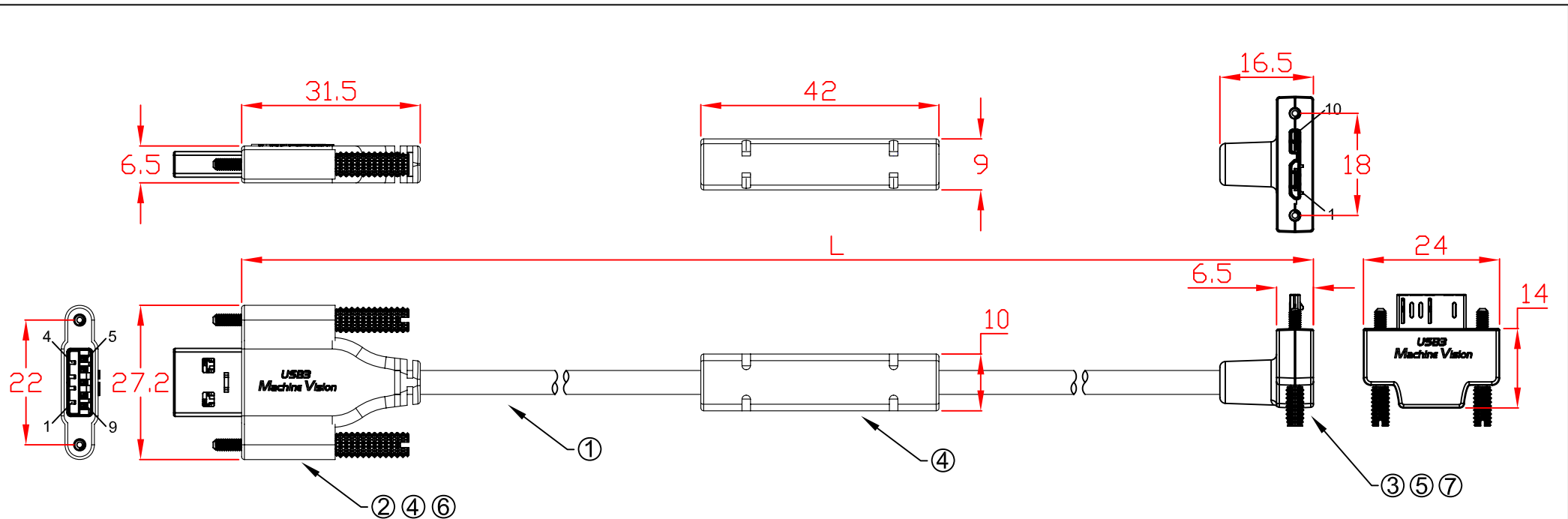

L:

CBL-USD302MBSS-4mDA	4000mm±30mm
CBL-USD302MBSS-5mDA	5000mm±30mm
CBL-USD302MBSS-6mDA	6000mm±30mm
CBL-USD302MBSS-7mDA	7000mm±30mm
CBL-USD302MBSS-8mDA	8000mm±30mm

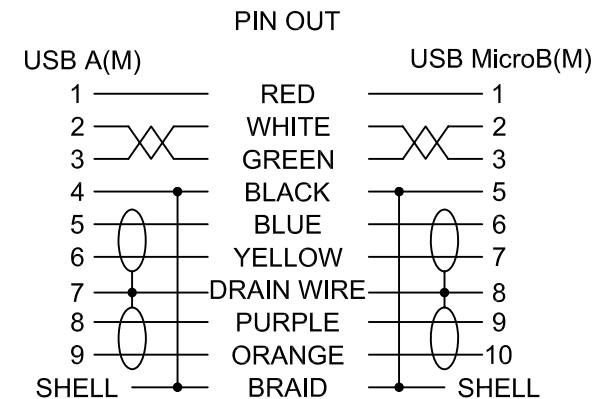

No	MATERIALS LIST:
1.	CABLE:UL2725 (32AWG*1PR+D+AM)x2C+32AWG*1PR+24AWG*1C+AM+B OD:4.2mm PVC JACKET COLOR:BLUE
2.	CONNECTOR:USB 3.0 A/M, 9P, BLUE INSULATOR SOLDER TYPE, NICKEL PLATED SHELL
3.	CONNECTOR:USB 3.0 MicroB/M, 10P, BLACK INSULATOR SOLDER TYPE, NICKEL PLATED SHELL
4.	PVC MOLDED HOUSING, BLUE COLOR
5.	ABS ASSEMBLY HOUSING, BLUE COLOR
6.	SCREW:#4x34.5 M2
7.	SCREW:#3x20.7 M2

Jargy part no.	Client part no.	Approved	SCALE	UNIT
CBL-USD302MBSS-XmDA			1 : 1	mm
Drawing Name		Drawn	Date	REV.
USB 3.0 A to Micro-B Cable M/M		<i>Kevin Hsu</i>	2016/06/04	1.0

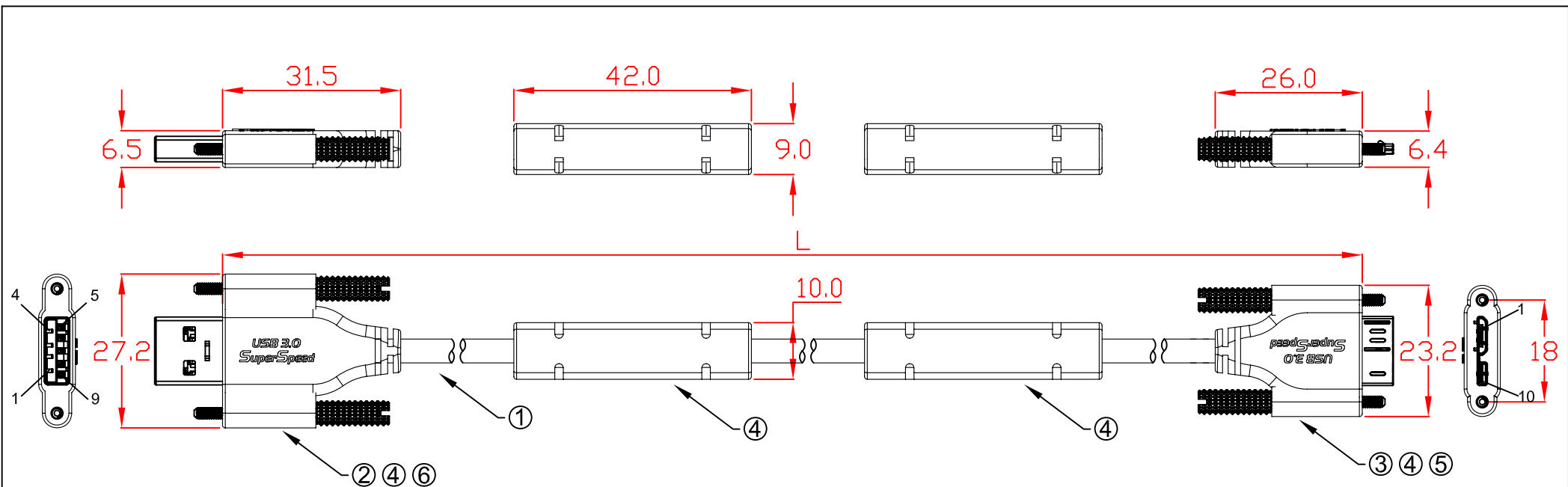

L:

CBL-USD302MBSS-9m	9000mm±30mm
CBL-USD302MBSS-10m	10000mm±30mm
CBL-USD302MBSS-11m	11000mm±30mm
CBL-USD302MBSS-12m	12000mm±30mm

PIN OUT

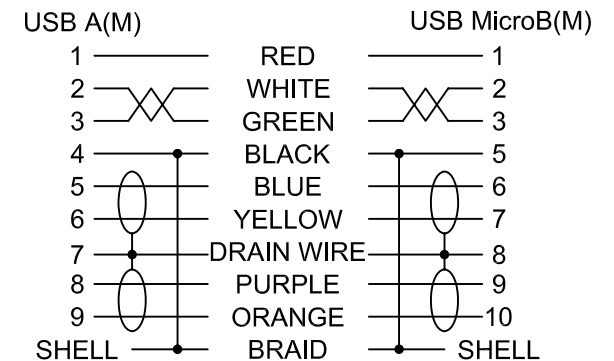

No	MATERIALS LIST:
1.	CABLE:UL2725 (32AWG*1PR+D+AM)x2C+32AWG*1PR+24AWG*1C+AM+B OD:4.2mm PVC JACKET COLOR:BLUE
2.	CONNECTOR:USB 3.0 A/M, 9P, BLUE INSULATOR SOLDER TYPE, NICKEL PLATED SHELL
3.	CONNECTOR:USB 3.0 MicroB/M, 10P, BLACK INSULATOR SOLDER TYPE, NICKEL PLATED SHELL
4.	PVC MOLDED HOUSING, BLUE COLOR
5.	SCREW:#4x33 M2
6.	SCREW:#4x34.5 M2

Jargy part no.	Client part no.	Approved	SCALE	UNIT
CBL-USD302MBSS-Xm			1 : 1	mm
Drawing Name		Drawn	Date	REV.
USB 3.0 A to MicroB Cable M/M		<i>Kevin Hsu</i>	2015/08/12	1.0

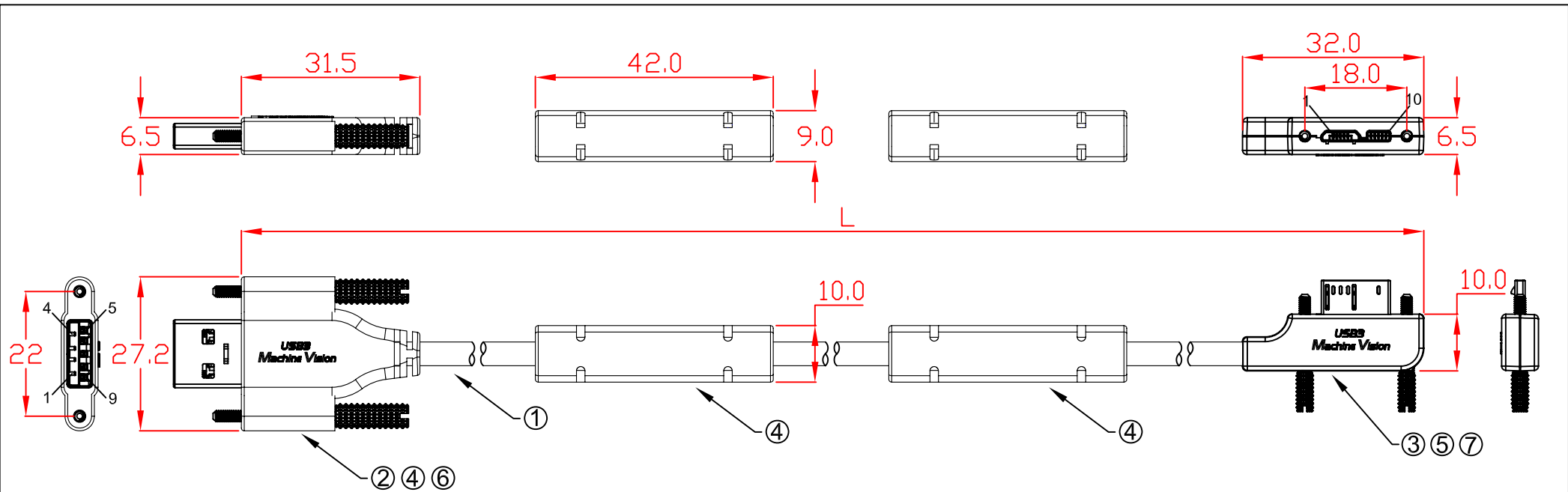

L:

CBL-USD302MBSS-9mLA	9000mm±50mm
CBL-USD302MBSS-10mLA	10000mm±50mm
CBL-USD302MBSS-11mLA	11000mm±50mm
CBL-USD302MBSS-12mLA	12000mm±50mm

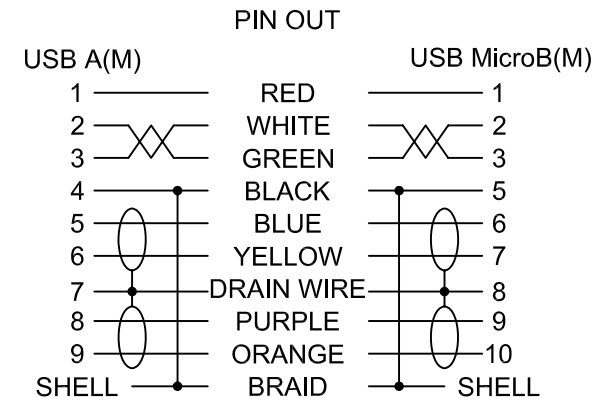

No	MATERIALS LIST:
1.	CABLE:UL2725 (32AWG*1PR+D+AM)x2C+32AWG*1PR+24AWG*1C+AM+B OD:4.2mm PVC JACKET COLOR:BLUE
2.	CONNECTOR:USB 3.0 A/M, 9P, BLUE INSULATOR SOLDER TYPE, NICKEL PLATED SHELL
3.	CONNECTOR:USB 3.0 MicroB/M, 10P, BLACK INSULATOR SOLDER TYPE, NICKEL PLATED SHELL
4.	PVC MOLDED HOUSING, BLUE COLOR
5.	ABS ASSEMBLY HOUSING, BLUE COLOR
6.	SCREW:#4x34.5 M2
7.	SCREW:#3x20.7 M2

Jargy part no.	Client part no.	Approved	SCALE	UNIT
CBL-USD302MBSS-XmLA			1 : 1	mm
Drawing Name		Drawn	Date	REV.
USB 3.0 A to Micro-B Cable M/M		<i>Kevin Hsu</i>	2016/06/06	1.0

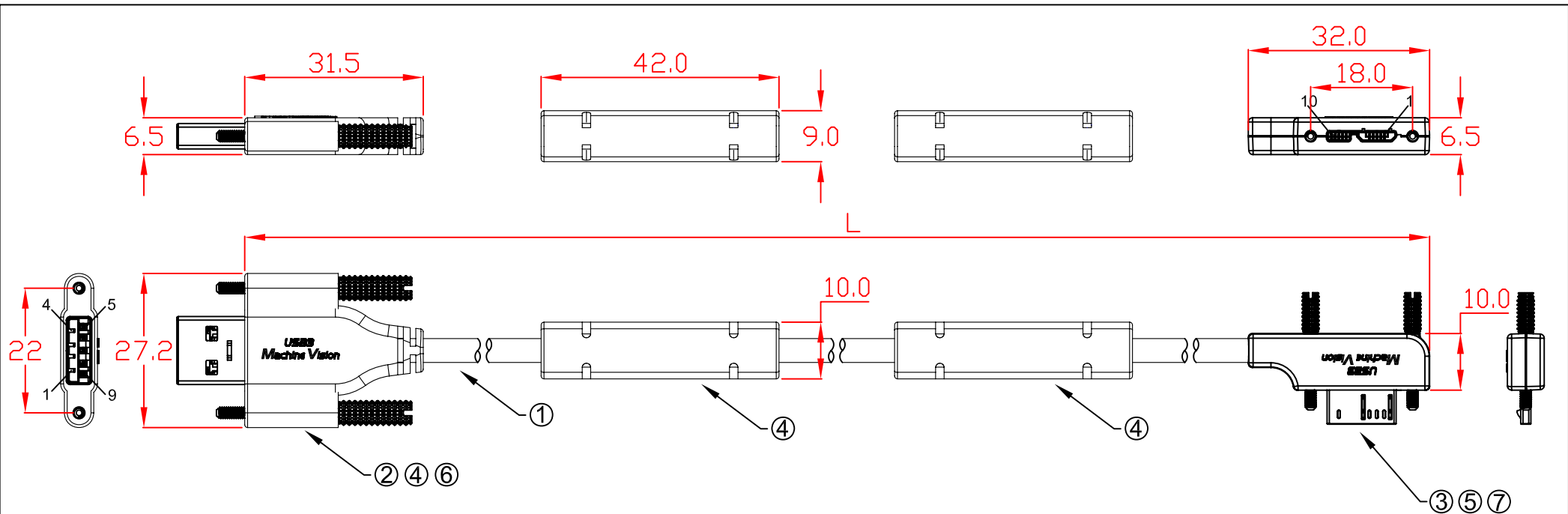

L:

CBL-USD302MBSS-9mRA	9000mm±50mm
CBL-USD302MBSS-10mRA	10000mm±50mm
CBL-USD302MBSS-11mRA	11000mm±50mm
CBL-USD302MBSS-12mRA	12000mm±50mm

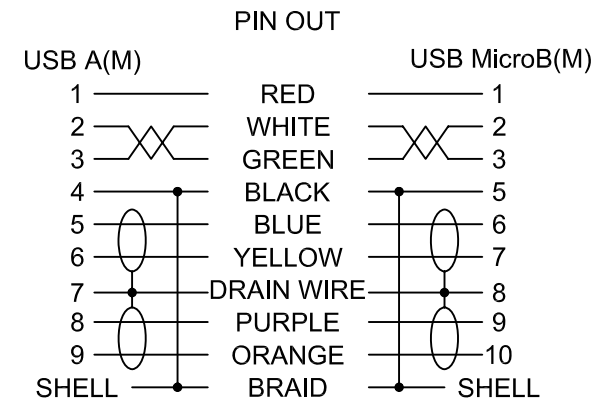

No	MATERIALS LIST:
1.	CABLE:UL2725 (32AWG*1PR+D+AM)x2C+32AWG*1PR+24AWG*1C+AM+B OD:4.2mm PVC JACKET COLOR:BLUE
2.	CONNECTOR:USB 3.0 A/M, 9P, BLUE INSULATOR SOLDER TYPE, NICKEL PLATED SHELL
3.	CONNECTOR:USB 3.0 MicroB/M, 10P, BLACK INSULATOR SOLDER TYPE, NICKEL PLATED SHELL
4.	PVC MOLDED HOUSING, BLUE COLOR
5.	ABS ASSEMBLY HOUSING, BLUE COLOR
6.	SCREW:#4x34.5 M2
7.	SCREW:#3x20.7 M2

Jargy part no.	Client part no.	Approved	SCALE	UNIT
CBL-USD302MBSS-XmRA			1 : 1	mm
Drawing Name		Drawn	Date	REV.
USB 3.0 A to Micro-B Cable M/M		<i>Kevin Hsu</i>	2016/06/06	1.0

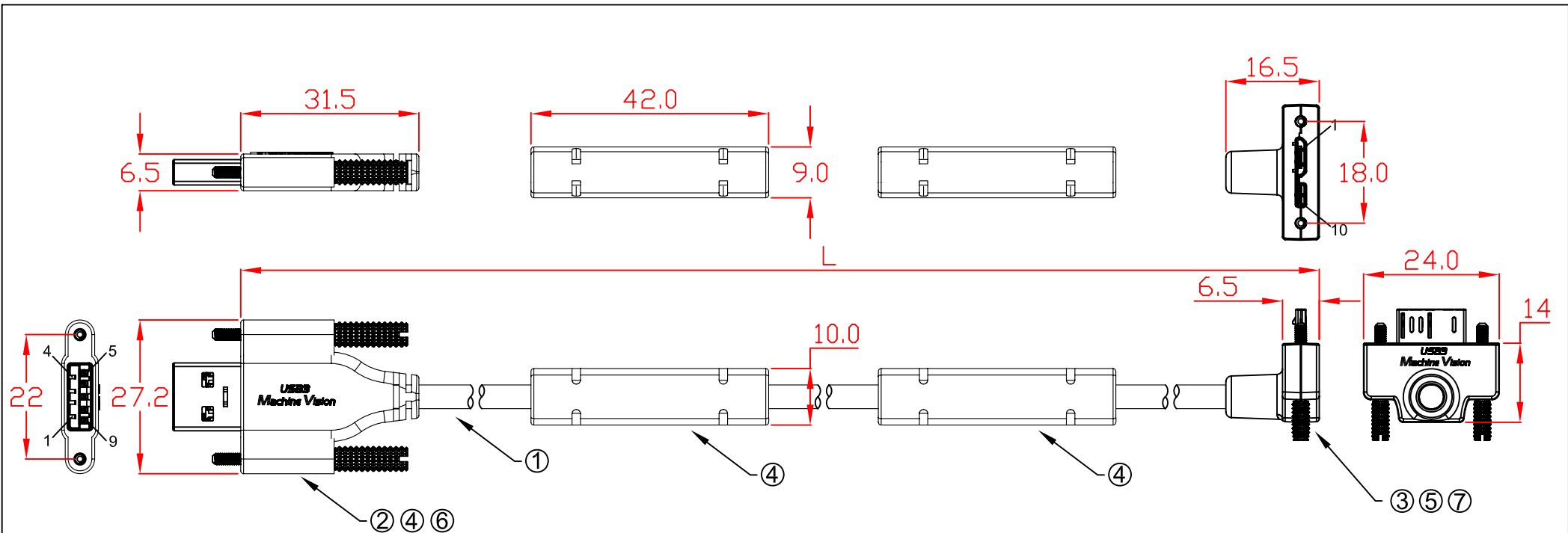

L:

- CBL-USD302MBSS-9mUA 9000mm±50mm
- CBL-USD302MBSS-10mUA 10000mm±50mm
- CBL-USD302MBSS-11mUA 11000mm±50mm
- CBL-USD302MBSS-12mUA 12000mm±50mm

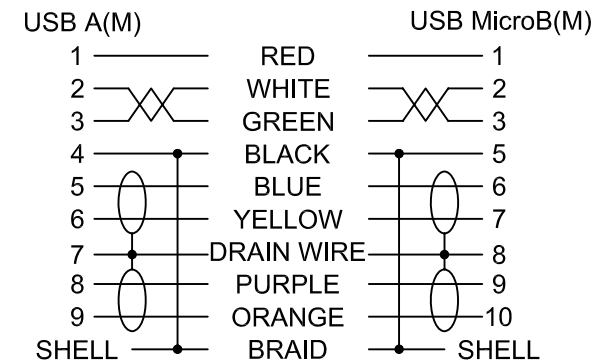

No	MATERIALS LIST:
1.	CABLE:UL2725 (32AWG*1PR+D+AM)x2C+32AWG*1PR+24AWG*1C+AM+B OD:4.2mm PVC JACKET COLOR:BLUE
2.	CONNECTOR:USB 3.0 A/M, 9P, BLUE INSULATOR SOLDER TYPE, NICKEL PLATED SHELL
3.	CONNECTOR:USB 3.0 MicroB/M, 10P, BLACK INSULATOR SOLDER TYPE, NICKEL PLATED SHELL
4.	PVC MOLDED HOUSING, BLUE COLOR
5.	ABS ASSEMBLY HOUSING, BLUE COLOR
6.	SCREW:#4x34.5 M2
7.	SCREW:#3x20.7 M2

Jargy part no.	Client part no.	Approved	SCALE	UNIT
CBL-USD302MBSS-XmUA			1 : 1	mm
Drawing Name		Drawn	Date	REV.
USB 3.0 A to Micro-B Cable M/M		<i>Kevin Hsu</i>	2016/06/06	1.0

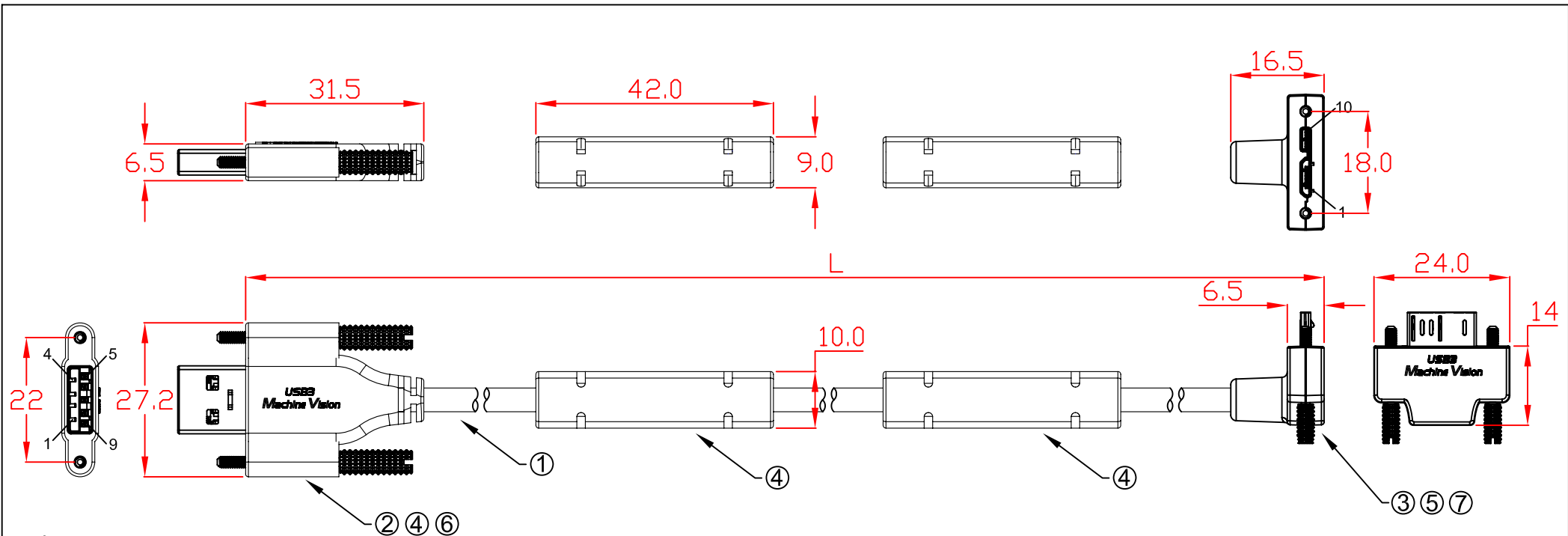

L:

CBL-USD302MBSS-9mDA	9000mm±50mm
CBL-USD302MBSS-10mDA	10000mm±50mm
CBL-USD302MBSS-11mDA	11000mm±50mm
CBL-USD302MBSS-12mDA	12000mm±50mm

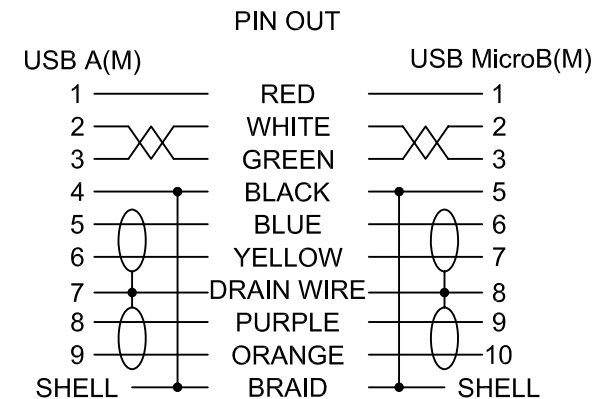

No	MATERIALS LIST:
1.	CABLE:UL2725 (32AWG*1PR+D+AM)x2C+32AWG*1PR+24AWG*1C+AM+B OD:4.2mm PVC JACKET COLOR:BLUE
2.	CONNECTOR:USB 3.0 A/M, 9P, BLUE INSULATOR SOLDER TYPE, NICKEL PLATED SHELL
3.	CONNECTOR:USB 3.0 MicroB/M, 10P, BLACK INSULATOR SOLDER TYPE, NICKEL PLATED SHELL
4.	PVC MOLDED HOUSING, BLUE COLOR
5.	ABS ASSEMBLY HOUSING, BLUE COLOR
6.	SCREW:#4x34.5 M2
7.	SCREW:#3x20.7 M2

Jargy part no.	Client part no.	Approved	SCALE	UNIT
CBL-USD302MBSS-XmDA			1 : 1	mm
Drawing Name		Drawn	Date	REV.
USB 3.0 A to Micro-B Cable M/M		<i>Kevin Hsu</i>	2016/06/06	1.0

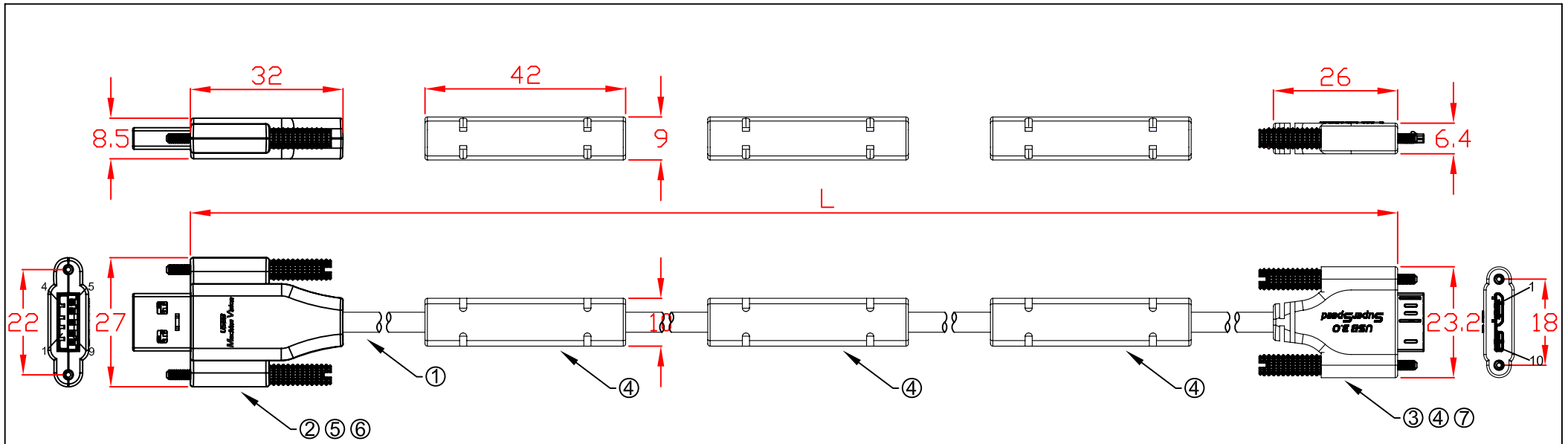

- L:
- CBL-USD302MBSS-13m 13000mm±50mm
  - CBL-USD302MBSS-14m 14000mm±50mm
  - CBL-USD302MBSS-15m 15000mm±50mm
  - CBL-USD302MBSS-16m 16000mm±50mm

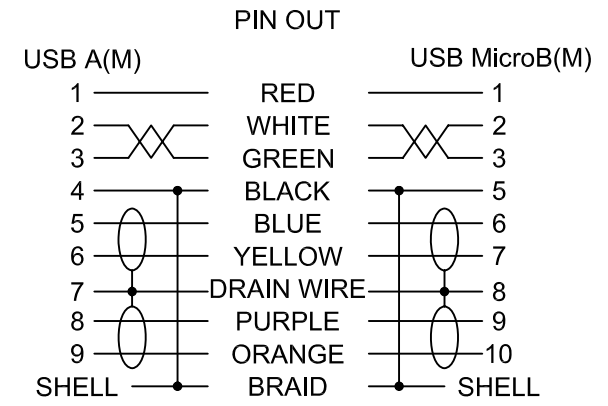

No	MATERIALS LIST:
1.	CABLE:UL2725 (32AWG*1PR+D+AM)x2C+32AWG*1PR+24AWG*1C+AM+B OD:4.2mm PVC JACKET COLOR:BLUE
2.	CONNECTOR:USB 3.0 A/M, 9P, BLUE INSULATOR SOLDER TYPE, NICKEL PLATED SHELL
3.	CONNECTOR:USB 3.0 MicroB/M, 10P, BLACK INSULATOR SOLDER TYPE, NICKEL PLATED SHELL
4.	PVC MOLDED HOUSING, BLUE COLOR
5.	ABS ASSEMBLY HOUSING, BLUE COLOR
6.	SCREW:#4x34.5 M2
7.	SCREW:#4x33 M2

Jargy part no.	Client part no.	Approved	SCALE	UNIT
CBL-USD302MBSS-Xm			1 : 2	mm
Drawing Name		Drawn	Date	REV.
USB 3.0 A to Micro-B Cable M/M		<i>Kevin Hsu</i>	2016/06/14	1.0



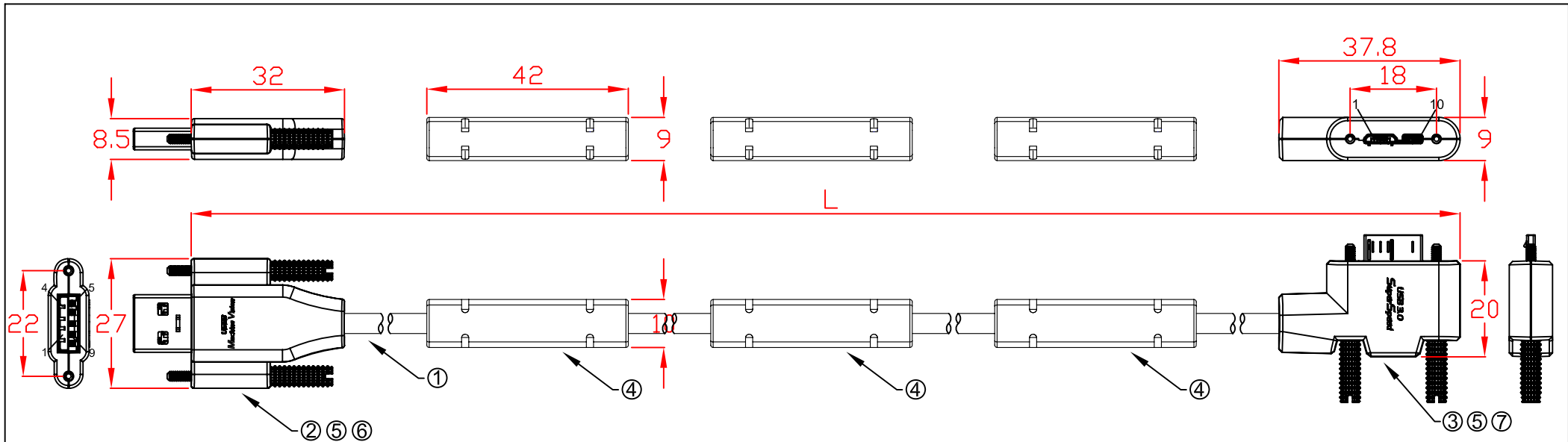

L:

- CBL-USD302MBSS-13mLA 13000mm±50mm
- CBL-USD302MBSS-14mLA 14000mm±50mm
- CBL-USD302MBSS-15mLA 15000mm±50mm
- CBL-USD302MBSS-16mLA 16000mm±50mm

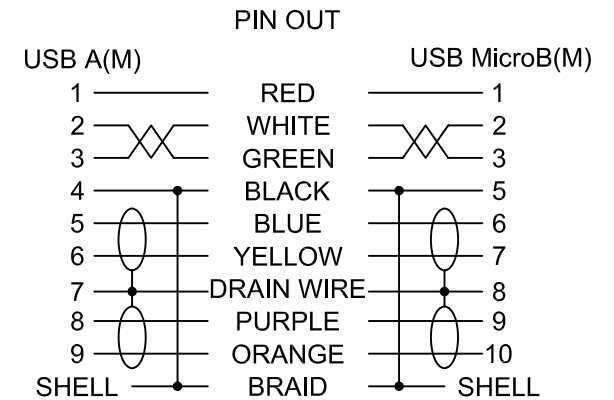

No	MATERIALS LIST:
1.	CABLE:UL2725 (32AWG*1PR+D+AM)x2C+32AWG*1PR+24AWG*1C+AM+B OD:4.2mm PVC JACKET COLOR:BLUE
2.	CONNECTOR:USB 3.0 A/M, 9P, BLUE INSULATOR SOLDER TYPE, NICKEL PLATED SHELL
3.	CONNECTOR:USB 3.0 MicroB/M, 10P, BLACK INSULATOR SOLDER TYPE, NICKEL PLATED SHELL
4.	PVC MOLDED HOUSING, BLUE COLOR
5.	ABS ASSEMBLY HOUSING, BLUE COLOR
6.	SCREW:#4x34.5 M2
7.	SCREW:#4x33 M2

Jargy part no.	Client part no.	Approved	SCALE	UNIT
CBL-USD302MBSS-XmLA			1 : 2	mm
Drawing Name		Drawn	Date	REV.
USB 3.0 A to Micro-B Cable M/M		<i>Kevin Hsu</i>	2016/06/06	1.0

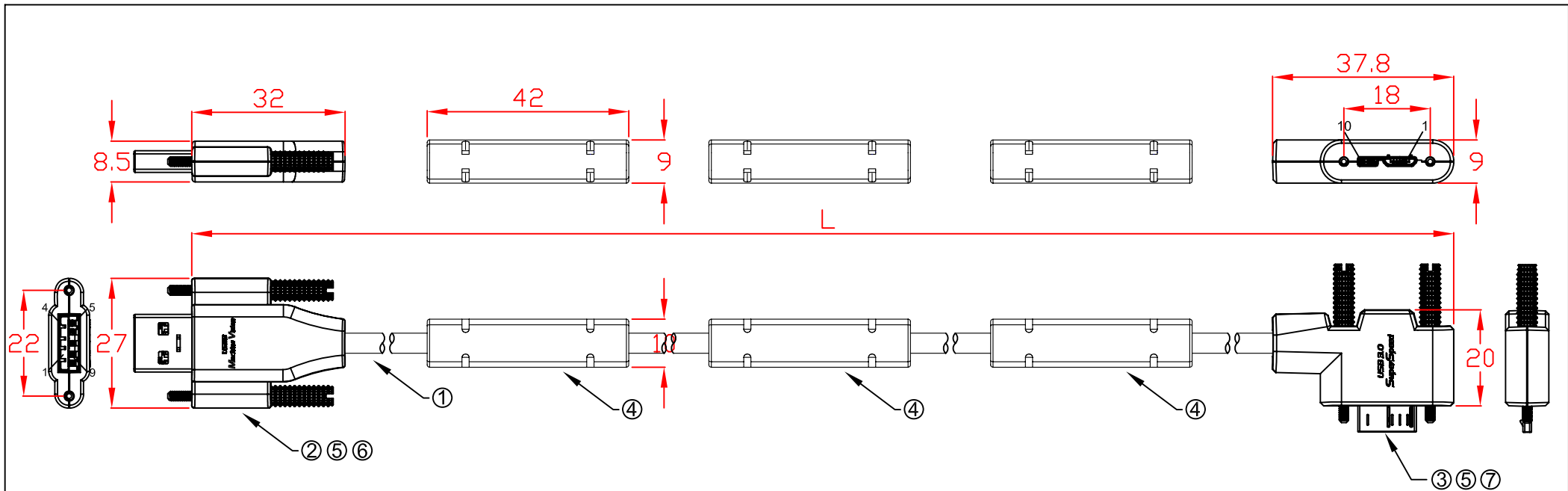

L:

CBL-USD302MBSS-13mRA	13000mm±50mm
CBL-USD302MBSS-14mRA	14000mm±50mm
CBL-USD302MBSS-15mRA	15000mm±50mm
CBL-USD302MBSS-16mRA	16000mm±50mm

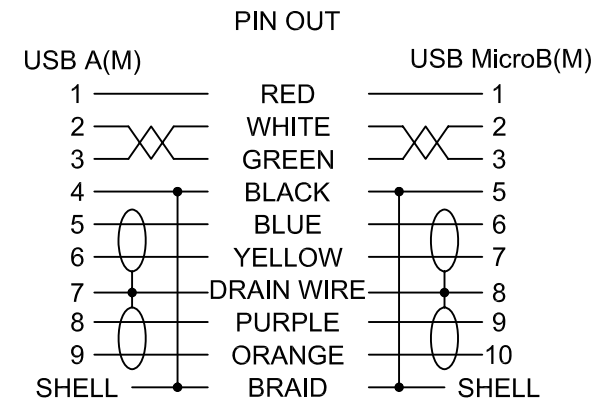

No	MATERIALS LIST:
1.	CABLE:UL2725 (32AWG*1PR+D+AM)x2C+32AWG*1PR+24AWG*1C+AM+B OD:4.2mm PVC JACKET COLOR:BLUE
2.	CONNECTOR:USB 3.0 A/M, 9P, BLUE INSULATOR SOLDER TYPE, NICKEL PLATED SHELL
3.	CONNECTOR:USB 3.0 MicroB/M, 10P, BLACK INSULATOR SOLDER TYPE, NICKEL PLATED SHELL
4.	PVC MOLDED HOUSING, BLUE COLOR
5.	ABS ASSEMBLY HOUSING, BLUE COLOR
6.	SCREW:#4x34.5 M2
7.	SCREW:#4x33 M2

Jargy part no.	Client part no.	Approved	SCALE	UNIT
CBL-USD302MBSS-XmRA			1 : 2	mm
Drawing Name		Drawn	Date	REV.
USB 3.0 A to Micro-B Cable M/M		<i>Kevin Hsu</i>	2016/06/06	1.0

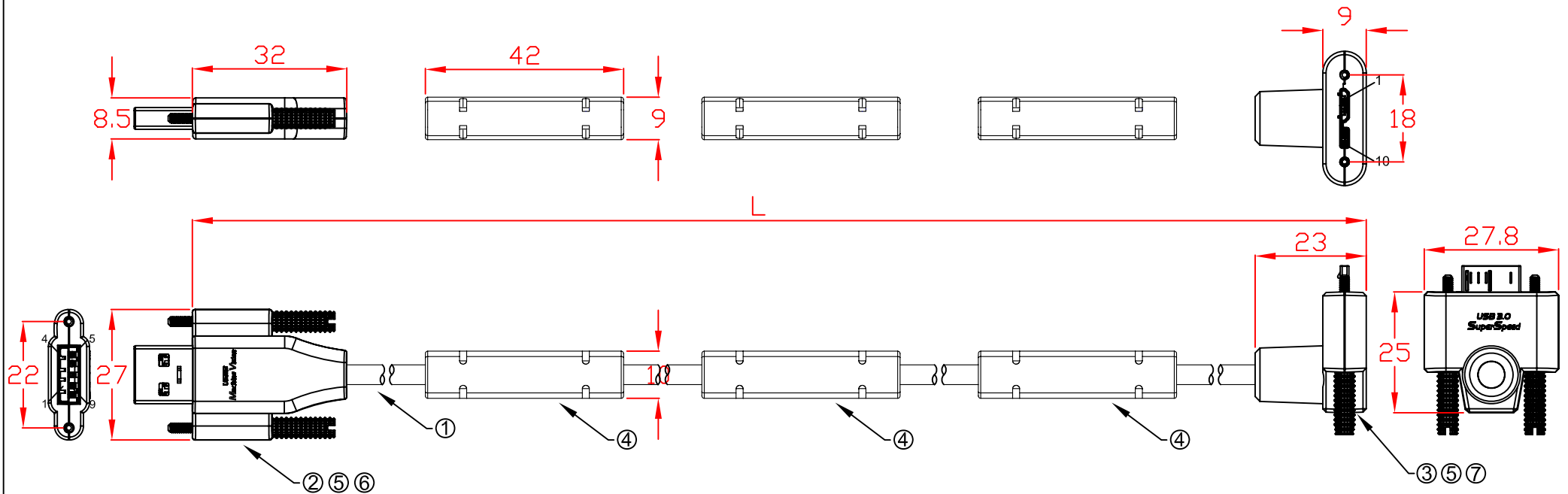

- L:
- CBL-USD302MBSS-13mUA 13000mm±50mm
  - CBL-USD302MBSS-14mUA 14000mm±50mm
  - CBL-USD302MBSS-15mUA 15000mm±50mm
  - CBL-USD302MBSS-16mUA 16000mm±50mm

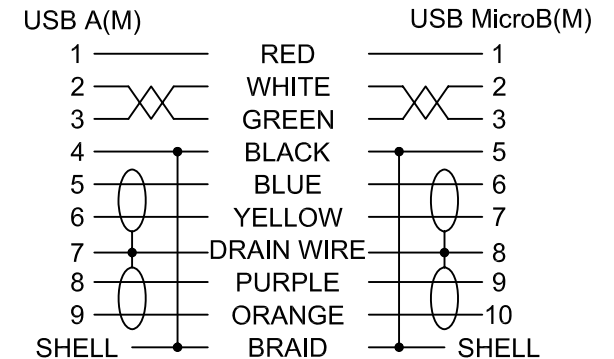

No	MATERIALS LIST:
1.	CABLE:UL2725 (32AWG*1PR+D+AM)x2C+32AWG*1PR+24AWG*1C+AM+B OD:4.2mm PVC JACKET COLOR:BLUE
2.	CONNECTOR:USB 3.0 A/M, 9P, BLUE INSULATOR SOLDER TYPE, NICKEL PLATED SHELL
3.	CONNECTOR:USB 3.0 MicroB/M, 10P, BLACK INSULATOR SOLDER TYPE, NICKEL PLATED SHELL
4.	PVC MOLDED HOUSING, BLUE COLOR
5.	ABS ASSEMBLY HOUSING, BLUE COLOR
6.	SCREW:#4x34.5 M2
7.	SCREW:#4x33 M2

Jargy part no.	Client part no.	Approved	SCALE	UNIT
CBL-USD302MBSS-XmUA			1 : 2	mm
Drawing Name		Drawn	Date	REV.
USB 3.0 A to Micro-B Cable M/M		<i>Kevin Hsu</i>	2016/06/06	1.0

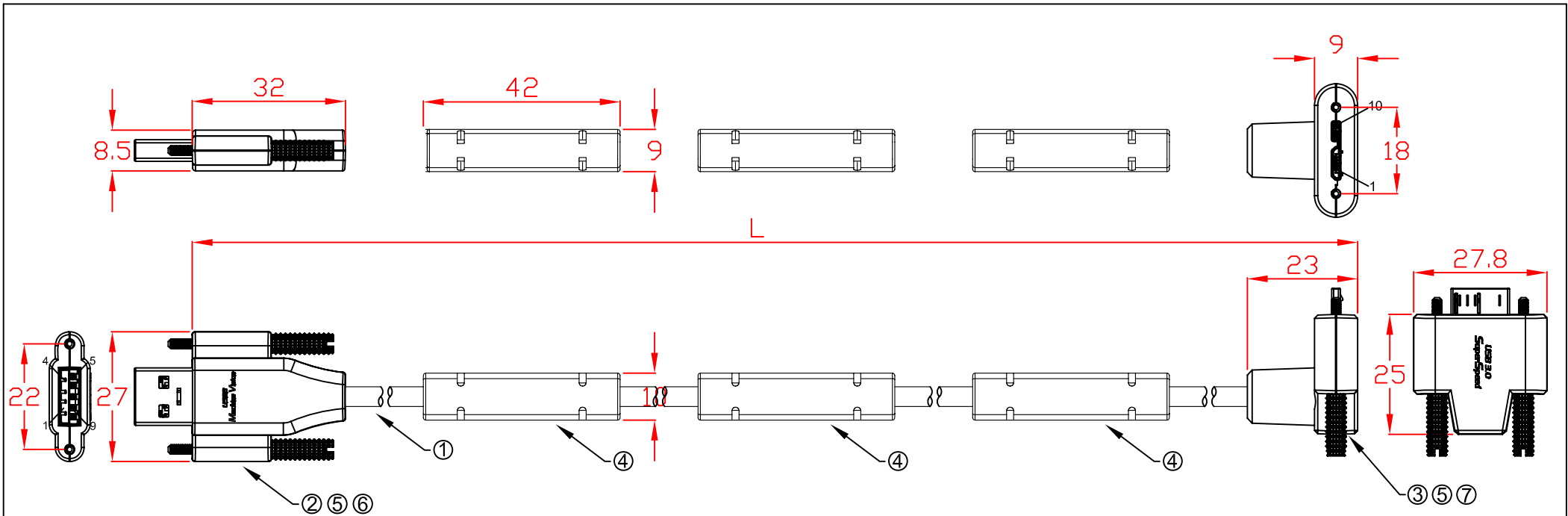

L:

- CBL-USD302MBSS-13mDA 13000mm±50mm
- CBL-USD302MBSS-14mDA 14000mm±50mm
- CBL-USD302MBSS-15mDA 15000mm±50mm
- CBL-USD302MBSS-16mDA 16000mm±50mm

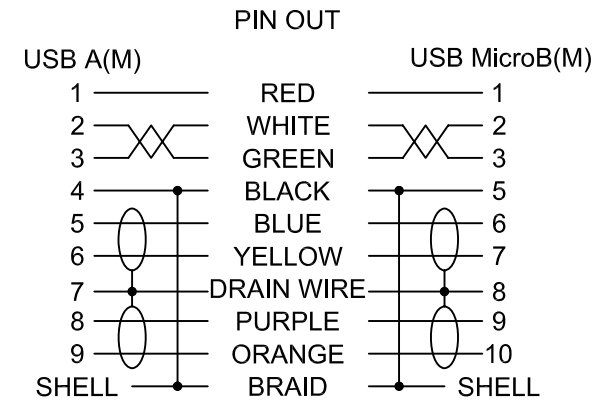

No	MATERIALS LIST:
1.	CABLE:UL2725 (32AWG*1PR+D+AM)x2C+32AWG*1PR+24AWG*1C+AM+B OD:4.2mm PVC JACKET COLOR:BLUE
2.	CONNECTOR:USB 3.0 A/M, 9P, BLUE INSULATOR SOLDER TYPE, NICKEL PLATED SHELL
3.	CONNECTOR:USB 3.0 MicroB/M, 10P, BLACK INSULATOR SOLDER TYPE, NICKEL PLATED SHELL
4.	PVC MOLDED HOUSING, BLUE COLOR
5.	ABS ASSEMBLY HOUSING, BLUE COLOR
6.	SCREW:#4x34.5 M2
7.	SCREW:#4x33 M2

Jargy part no.	Client part no.	Approved	SCALE	UNIT
CBL-USD302MBSS-XmDA			1 : 2	mm
Drawing Name		Drawn	Date	REV.
USB 3.0 A to Micro-B Cable M/M		<i>Kevin Hsu</i>	2016/06/06	1.0

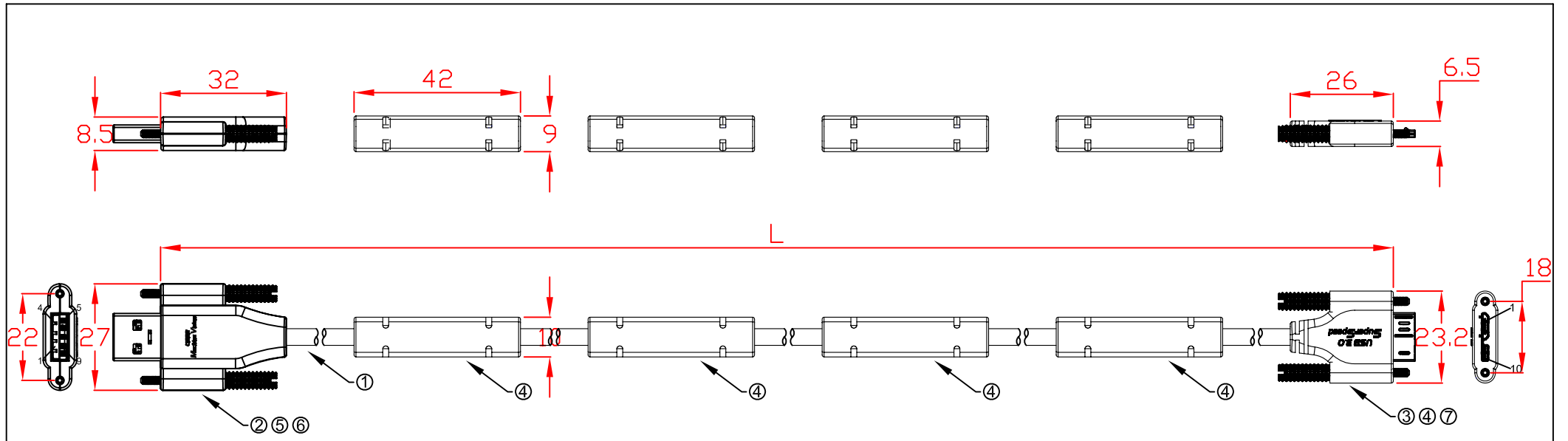

- L:
- CBL-USD302MBSS-17m 17000mm±50mm
  - CBL-USD302MBSS-18m 18000mm±50mm
  - CBL-USD302MBSS-19m 19000mm±50mm
  - CBL-USD302MBSS-20m 20000mm±50mm

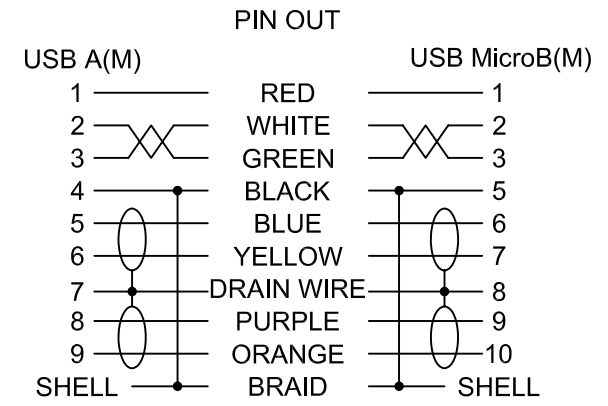

No	MATERIALS LIST:
1.	CABLE:UL2725 (32AWG*1PR+D+AM)x2C+32AWG*1PR+24AWG*1C+AM+B OD:4.2mm PVC JACKET COLOR:BLUE
2.	CONNECTOR:USB 3.0 A/M, 9P, BLUE INSULATOR SOLDER TYPE, NICKEL PLATED SHELL
3.	CONNECTOR:USB 3.0 MicroB/M, 10P, BLACK INSULATOR SOLDER TYPE, NICKEL PLATED SHELL
4.	PVC MOLDED HOUSING, BLUE COLOR
5.	ABS ASSEMBLY HOUSING, BLUE COLOR
6.	SCREW:#4x34.5 M2
7.	SCREW:#4x33 M2

Jargy part no.	Client part no.	Approved	SCALE	UNIT
CBL-USD302MBSS-Xm			1 : 2	mm
Drawing Name		Drawn	Date	REV.
USB 3.0 A to Micro-B Cable M/M		<i>Kevin Hsu</i>	2016/06/14	1.0

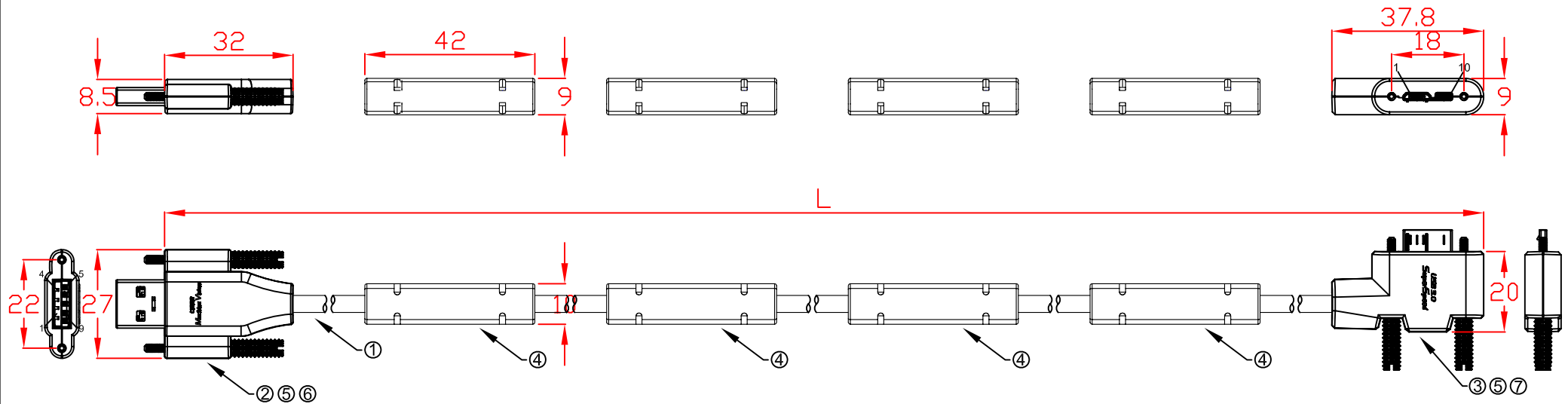

- L:
- CBL-USD302MBSS-17mLA 17000mm±50mm
  - CBL-USD302MBSS-18mLA 18000mm±50mm
  - CBL-USD302MBSS-19mLA 19000mm±50mm
  - CBL-USD302MBSS-20mLA 20000mm±50mm

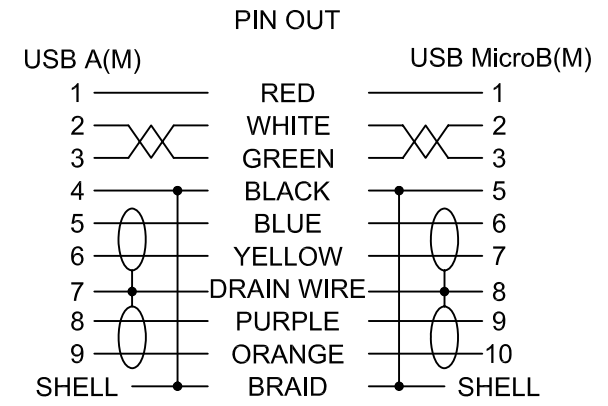

No	MATERIALS LIST:
1.	CABLE:UL2725 (32AWG*1PR+D+AM)x2C+32AWG*1PR+24AWG*1C+AM+B OD:4.2mm PVC JACKET COLOR:BLUE
2.	CONNECTOR:USB 3.0 A/M, 9P, BLUE INSULATOR SOLDER TYPE, NICKEL PLATED SHELL
3.	CONNECTOR:USB 3.0 MicroB/M, 10P, BLACK INSULATOR SOLDER TYPE, NICKEL PLATED SHELL
4.	PVC MOLDED HOUSING, BLUE COLOR
5.	ABS ASSEMBLY HOUSING, BLUE COLOR
6.	SCREW:#4x34.5 M2
7.	SCREW:#4x33 M2

Jargy part no.	Client part no.	Approved	SCALE	UNIT
CBL-USD302MBSS-XmLA			1 : 2	mm
Drawing Name		Drawn	Date	REV.
USB 3.0 A to Micro-B Cable M/M		<i>Kevin Hsu</i>	2016/06/06	1.0

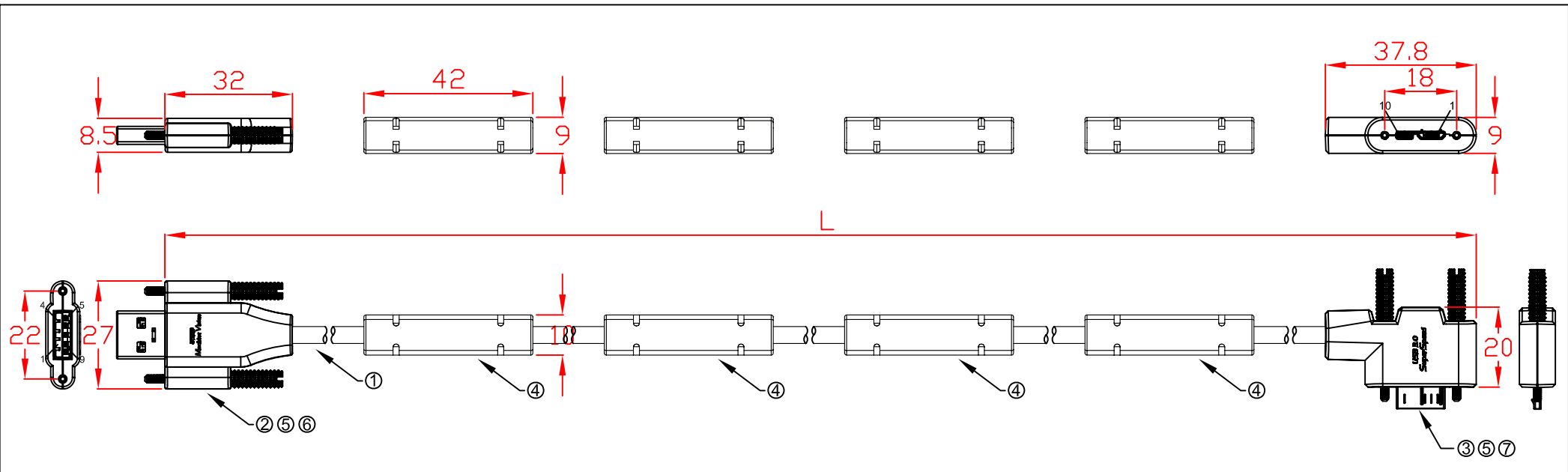

L:

CBL-USD302MBSS-17mRA	17000mm±50mm
CBL-USD302MBSS-18mRA	18000mm±50mm
CBL-USD302MBSS-19mRA	19000mm±50mm
CBL-USD302MBSS-20mRA	20000mm±50mm

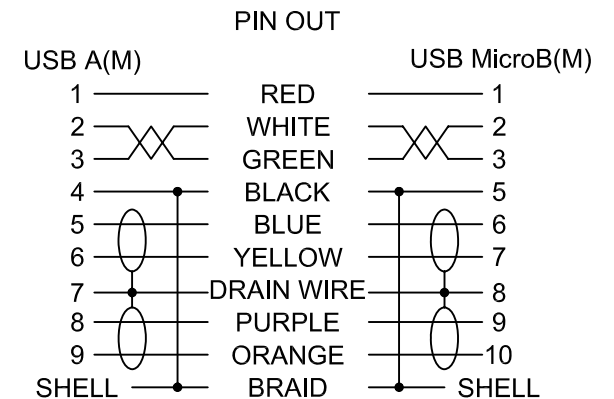

No	MATERIALS LIST:
1.	CABLE:UL2725 (32AWG*1PR+D+AM)x2C+32AWG*1PR+24AWG*1C+AM+B OD:4.2mm PVC JACKET COLOR:BLUE
2.	CONNECTOR:USB 3.0 A/M, 9P, BLUE INSULATOR SOLDER TYPE, NICKEL PLATED SHELL
3.	CONNECTOR:USB 3.0 MicroB/M, 10P, BLACK INSULATOR SOLDER TYPE, NICKEL PLATED SHELL
4.	PVC MOLDED HOUSING, BLUE COLOR
5.	ABS ASSEMBLY HOUSING, BLUE COLOR
6.	SCREW:#4x34.5 M2
7.	SCREW:#4x33 M2

Jargy part no.	Client part no.	Approved	SCALE	UNIT
CBL-USD302MBSS-XmRA			1 : 2	mm
Drawing Name		Drawn	Date	REV.
USB 3.0 A to Micro-B Cable M/M		<i>Kevin Hsu</i>	2016/06/06	1.0

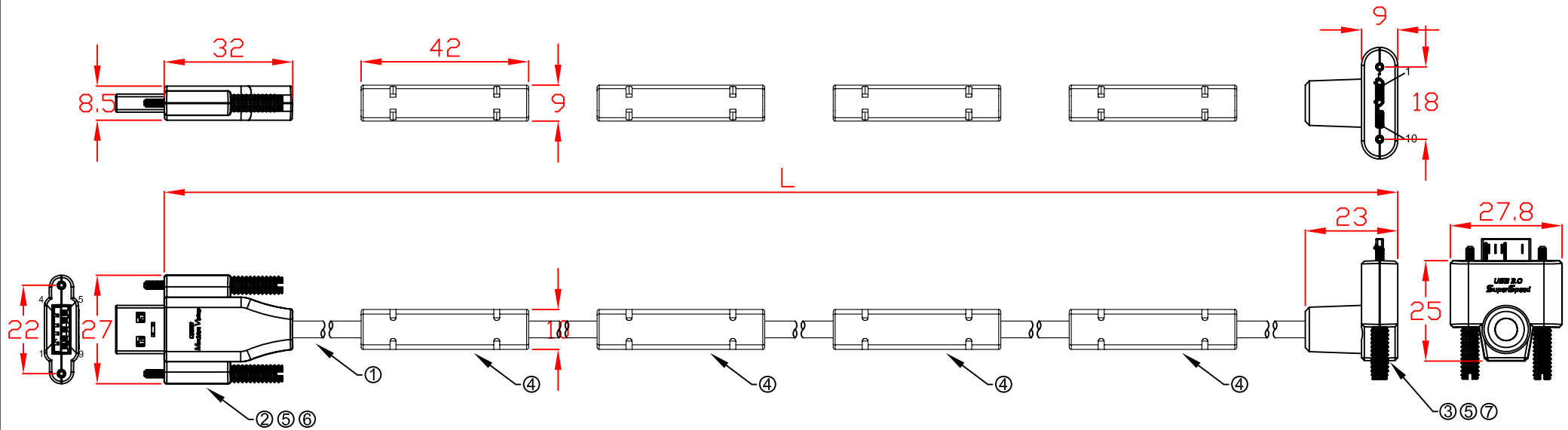

L:

- CBL-USD302MBSS-17mUA 17000mm±50mm
- CBL-USD302MBSS-18mUA 18000mm±50mm
- CBL-USD302MBSS-19mUA 19000mm±50mm
- CBL-USD302MBSS-20mUA 20000mm±50mm

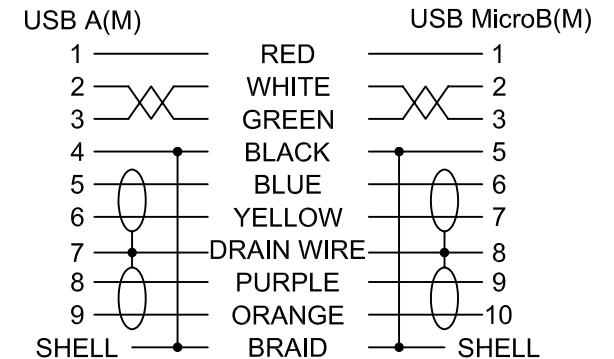

No	MATERIALS LIST:
1.	CABLE:UL2725 (32AWG*1PR+D+AM)x2C+32AWG*1PR+24AWG*1C+AM+B OD:4.2mm PVC JACKET COLOR:BLUE
2.	CONNECTOR:USB 3.0 A/M, 9P, BLUE INSULATOR SOLDER TYPE, NICKEL PLATED SHELL
3.	CONNECTOR:USB 3.0 MicroB/M, 10P, BLACK INSULATOR SOLDER TYPE, NICKEL PLATED SHELL
4.	PVC MOLDED HOUSING, BLUE COLOR
5.	ABS ASSEMBLY HOUSING, BLUE COLOR
6.	SCREW:#4x34.5 M2
7.	SCREW:#4x33 M2

Jargy part no.	Client part no.	Approved	SCALE	UNIT
CBL-USD302MBSS-XmUA			1 : 2	mm
Drawing Name		Drawn	Date	REV.
USB 3.0 A to Micro-B Cable M/M		<i>Kevin Hsu</i>	2016/06/06	1.0



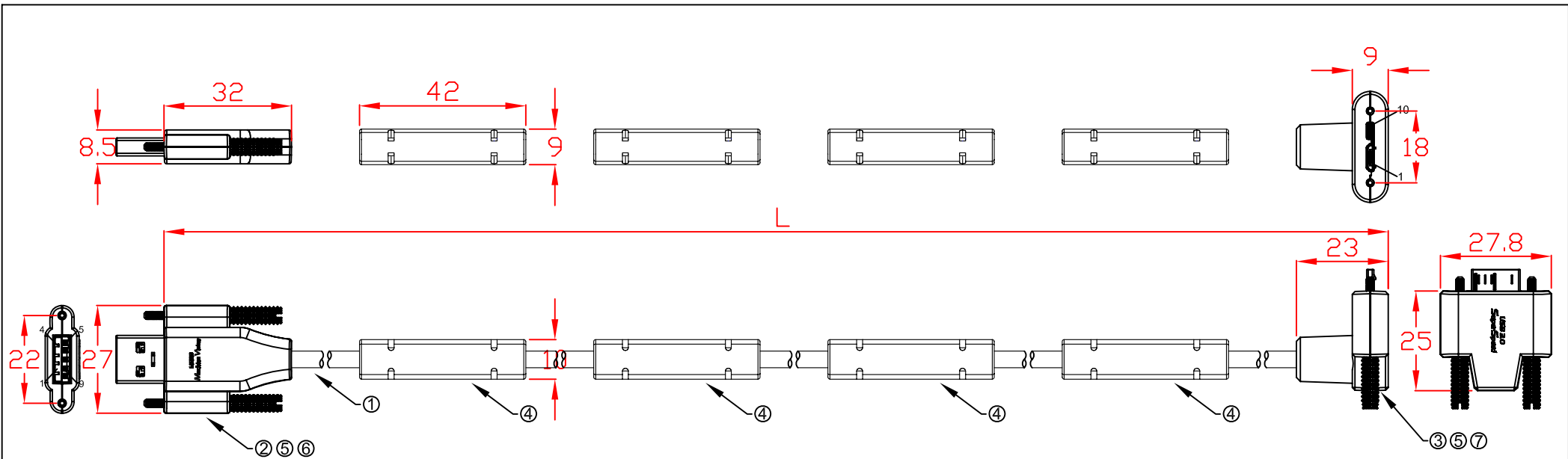

L:

- CBL-USD302MBSS-17mDA 17000mm±50mm
- CBL-USD302MBSS-18mDA 18000mm±50mm
- CBL-USD302MBSS-19mDA 19000mm±50mm
- CBL-USD302MBSS-20mDA 20000mm±50mm

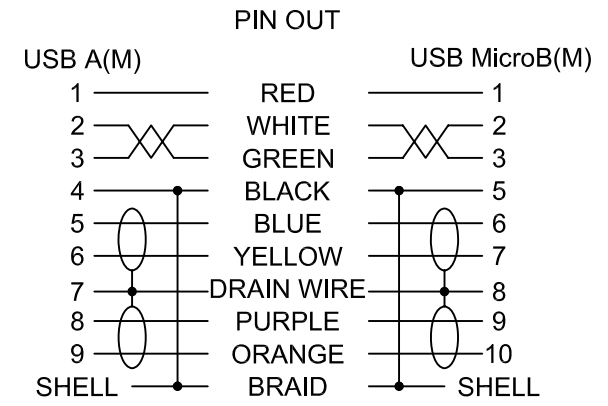

No	MATERIALS LIST:
1.	CABLE:UL2725 (32AWG*1PR+D+AM)x2C+32AWG*1PR+24AWG*1C+AM+B OD:4.2mm PVC JACKET COLOR:BLUE
2.	CONNECTOR:USB 3.0 A/M, 9P, BLUE INSULATOR SOLDER TYPE, NICKEL PLATED SHELL
3.	CONNECTOR:USB 3.0 MicroB/M, 10P, BLACK INSULATOR SOLDER TYPE, NICKEL PLATED SHELL
4.	PVC MOLDED HOUSING, BLUE COLOR
5.	ABS ASSEMBLY HOUSING, BLUE COLOR
6.	SCREW:#4x34.5 M2
7.	SCREW:#4x33 M2

Jargy part no.	Client part no.	Approved	SCALE	UNIT
CBL-USD302MBSS-XmDA			1 : 2	mm
Drawing Name		Drawn	Date	REV.
USB 3.0 A to Micro-B Cable M/M		<i>Kevin Hsu</i>	2016/06/06	1.0